

# KONA IP

Transport, Capture, Display

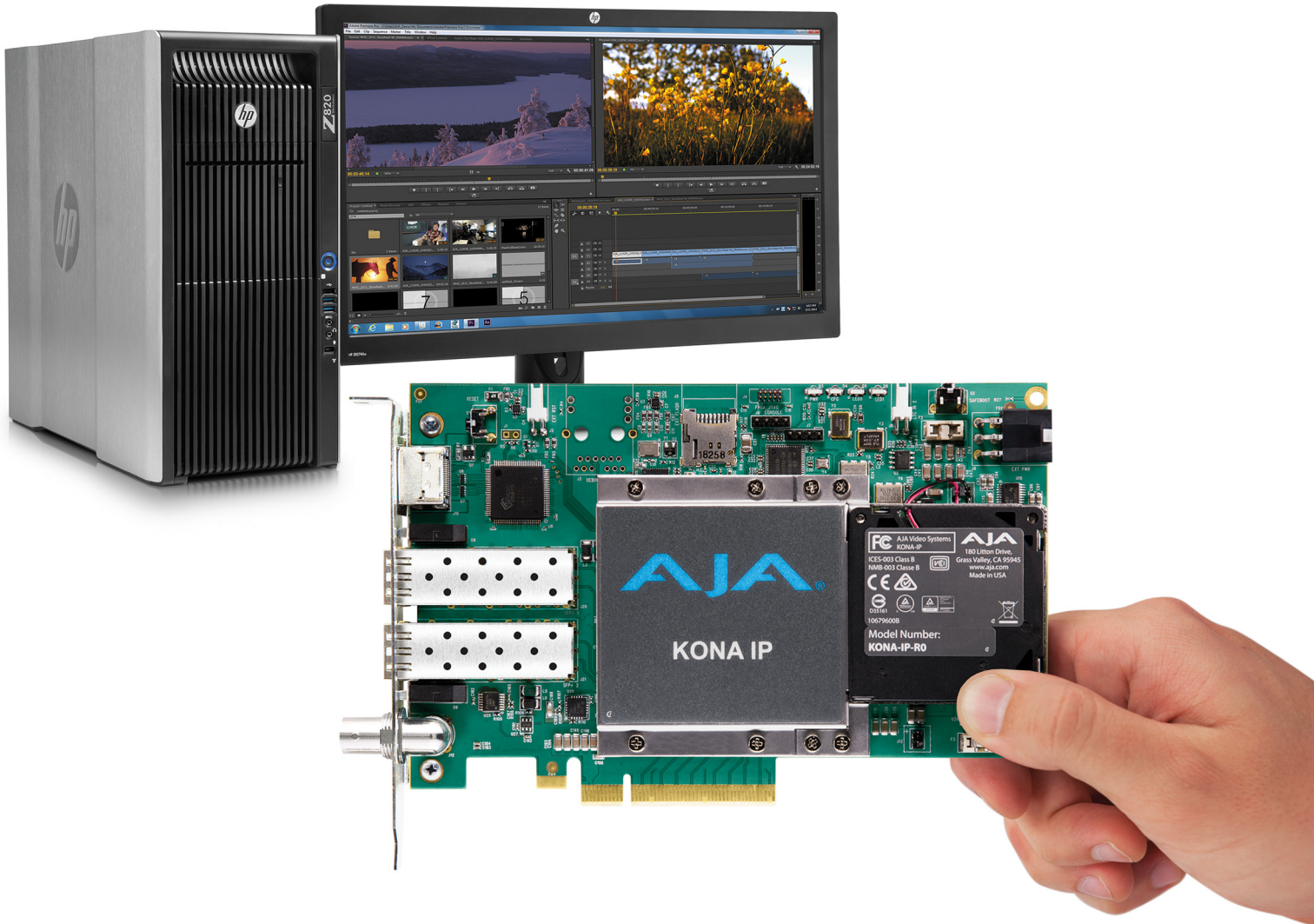

## Installation and Operation Manual

Version 16.1  
Published July 14, 2021



# Notices

---

## Trademarks

---

AJA® and Because it matters.® are registered trademarks of AJA Video Systems, Inc. for use with most AJA products. AJA™ is a trademark of AJA Video Systems, Inc. for use with recorder, router, software and camera products. Because it matters.™ is a trademark of AJA Video Systems, Inc. for use with camera products.

Corvid Ultra®, Io®, Ki Pro®, KONA®, KUMO®, ROI® and T-Tap® are registered trademarks of AJA Video Systems, Inc.

AJA Control Room™, KiStor™, Science of the Beautiful™, TruScale™, V2Analog™ and V2Digital™ are trademarks of AJA Video Systems, Inc.

All other trademarks are the property of their respective owners.

## Copyright

---

Copyright © 2021 AJA Video Systems, Inc. All rights reserved. All information in this manual is subject to change without notice. No part of the document may be reproduced or transmitted in any form, or by any means, electronic or mechanical, including photocopying or recording, without the express written permission of AJA Video Systems, Inc.

## Contacting AJA Support

---

When calling for support, have all information at hand prior to calling. To contact AJA for sales or support, use any of the following methods:

Telephone	+1.530.271.3190
FAX	+1.530.271.3140
Web	<a href="https://www.aja.com">https://www.aja.com</a>
Support Email	<a href="mailto:support@aja.com">support@aja.com</a>
Sales Email	<a href="mailto:sales@aja.com">sales@aja.com</a>

# Contents

---

Notices . . . . .	2
Trademarks . . . . .	2
Copyright . . . . .	2
Contacting AJA Support . . . . .	2
<b>Chapter 1 – Introduction . . . . .</b>	<b>5</b>
Overview . . . . .	5
About IP Media Transports . . . . .	5
AJA Software & Utilities . . . . .	7
Network Requirements . . . . .	8
System Requirements . . . . .	9
Disk Storage Methods . . . . .	9
KONA IP Features . . . . .	10
KONA IP Connectors . . . . .	11
In This Manual . . . . .	11
<b>Chapter 2 – Installation . . . . .</b>	<b>13</b>
Installation Overview . . . . .	13
AJA System Test Application . . . . .	13
Unpacking . . . . .	13
Shipping Box Contents . . . . .	13
Installing the KONA Card . . . . .	14
Cabling the System . . . . .	14
KONA IP Cable Connections . . . . .	14
Installing KONA Software . . . . .	16
NMOS Installation . . . . .	16
macOS Installations . . . . .	16
Types of KONA IP Firmware . . . . .	17
Unicast and Multicast Support . . . . .	17
<b>Chapter 3 – Operation . . . . .</b>	<b>18</b>
Using KONA with Professional Video /Audio Software . . . . .	18
Capture Formats . . . . .	18
AJA Control Panel Overview . . . . .	18
AJA Control Panel Operating Modes . . . . .	18
AJA Control Panel User Interface . . . . .	19
Controlling Application . . . . .	21
Presets . . . . .	22
Default Preferences . . . . .	22
Using Multiple AJA Devices . . . . .	24
Function Screens . . . . .	24
About KONA IP Modal Operation . . . . .	25
Control Panel Operation in ST 2022-6 Mode . . . . .	26
Control Screen . . . . .	26
Format Screen . . . . .	28
Input Select Screen . . . . .	29
Output Select Screen . . . . .	30
HDMI Screen . . . . .	31
HDR Screen . . . . .	33
Video Setup Screen . . . . .	35
Audio Setup Screen . . . . .	36
Audio Mixer Screen . . . . .	37
Audio Mixer Playback Monitor Tab . . . . .	38
Audio Mixer Capture Monitor Tab . . . . .	39
IP Network Screen . . . . .	40
IP Input Screen . . . . .	42
Downstream Keyer Screen . . . . .	44
LUT Screen . . . . .	46
Timecode Screen . . . . .	49

Presets Screen . . . . .	50
Firmware Screen . . . . .	51
Info Screen . . . . .	52
Control Panel Operation in ST 2110 Mode . . . . .	52
Overview . . . . .	52
General Operation . . . . .	52
IP Config Status Tab . . . . .	53
IP Config Capture Tab . . . . .	54
IP Config Playback Tab. . . . .	56
IP Config Editor Window . . . . .	57
<b>Chapter 4 – Advanced ST 2110 Configuration . . . . .</b>	<b>59</b>
Configuration Summary . . . . .	59
Initial KONA IP ST 2110 Installation and Network Configuration . . . . .	59
Transmit/Receive Example . . . . .	61
AJA NMOS Controls . . . . .	62
Transmit Redundancy with ST 2110 via ST 2022-7 . . . . .	62
For JSON Configuration (Transmit only). . . . .	62
Guidance for SMPTE ST 2110-23 . . . . .	62
For JSON Configuration. . . . .	62
For SDPs. . . . .	62
<b>Appendix A – Specifications . . . . .</b>	<b>64</b>
KONA IP Tech Specs . . . . .	64
<b>Appendix B – Safety &amp; Compliance. . . . .</b>	<b>67</b>
<b>Warranty and Liability Information . . . . .</b>	<b>74</b>
<b>Index. . . . .</b>	<b>75</b>

# Chapter 1 – Introduction

---

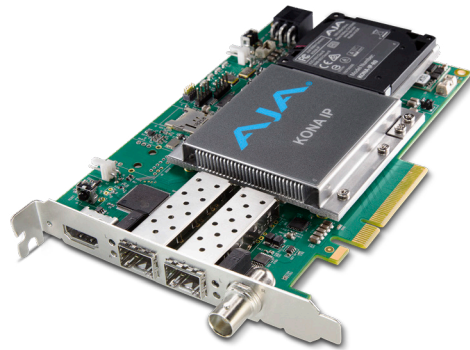

## Overview

---

KONA IP is a powerful video and audio I/O card for professional IP based workflows. As part of AJA's industry leading KONA line of PCIe capture and playback cards, KONA IP works seamlessly with the most popular creative software applications, such as Adobe Premiere® Pro, Apple FCP X, Avid Media Composer®.

Designed as a flexible platform with support for SMPTE ST 2022-6 and ST 2110 uncompressed IP video/audio workflows, KONA IP brings the highest quality 4K/UltraHD, 2K, HD, and SD video and audio over IP to computers running Mac, Windows or Linux Operating Systems. KONA IP can also support 4K p60 (2SI) capture or playback, via SMPTE ST 2110-23.

KONA IP is also supported through the very same SDK as the rest of the KONA family, making it straight forward for developers to make the transition to Video over IP.

## About IP Media Transports

---

IP media transport can take various forms, with differing capabilities and requirements. Two basic IP mechanisms are supported by KONA IP cards: Unicast (point to point transport) and Multicast (single source to multiple destination transport). Different IP address configurations are required for each of these methods.

The KONA IP card is equipped with two SFP cages, requiring one or two optionally purchased SFP modules that are compatible with you intended application.

Other transport variations include:

### ST 2022-6

---

This transport passes full resolution SDI material over a network using IP technology. Because the content is not compressed, 10 GigE throughput on the IP Ethernet network is required. The entire SDI signal (video, audio, metadata) is transported as a single stream.

## ST 2110

---

This transport passes full resolution SDI material, and so requires a 10 GigE IP Ethernet network, but the major components of an SDI signal can be transported separately (for example, only the embedded audio of an SDI signal can be sent to one location, like a DAW). 2110 transport requires 10 GigE Ethernet switches, or larger.

Because the separately transported SDI signals may eventually need to be re-synchronized, a Precision Time Protocol (PTP) server-based network timing system is required.

SMPTE standards supported by KONA IP:

- 2110-10 (System Timing)
- 2110-20 (Uncompressed video)
- 2110-21 (Traffic shaping for Uncompressed video)
- 2110-23 (4K p60 in or out using both 10GbE SFPs in tandem, no pass-through, no 2022-7 support)
- 2110-30 (PCM Audio)
- 2110-40 (Ancillary Data)

Because it can be complicated to devise the IP configurations required to manage ST 2110 transport streams in a facility, AJA supports three configuration methods: JavaScript Object Notation (JSON) file, Session Description Protocol (SDP) file, and SDP URL. These methods permit the user to easily re-configure their KONA IP to acquire the signals they need over the network even if they are not experienced IP network engineers, provided the JSON or SDP files have been created by experts and then made available to the user.

For Transmit only, ST 2022-7 is also supported for ST 2110, providing a mechanism to also provide redundancy in playout for those environments too.

Multiple audio tracks, and ST 2110-23 using multiple video streams, are simplified via SDP grouping.

## ST 2022-7

---

ST 2022-7 refers to redundancy and / or other packet-level protections for either ST 2022-6 or ST 2110. With ST 2022-7 two identical signals can be sent along physically different network paths, meaning that the delivery is protected even if one leg of the network experiences an interruption or downtime. Indeed, 24x7 operations often have to plan these outages so that maintenance can take place on one side of the network while transmission continues.

*NOTE: ST 2022-7 support for ST 2110 is for transmit only. ST 2022-7 support for ST 2022-6 is for both receive and transmit.*

## NMOS

---

NMOS is a mechanism for providing discovery, registration and control in ST 2110 environments. A separate application, "AJA NMOS", supports automatic discovery of IP devices on the network, using an app (daemon) that operates in the background with minimal user configuration. The first AJA device accessed by the computer running the daemon can be discovered and subject to control by an external NMOS network control application. NMOS uses the IP address of the host machine for communications.

Generally, NMOS works as follows:

- When KONA IP starts up, the NMOS app actively scans the network for an NMOS registry using MDNS/DNS. If found, the NMOS registry is informed who the KONA IP device is, and its capabilities.
- If during startup the NMOS registry is not found, the NMOS app continues to announce KONA IP's presence via MDNS so that it can later be discovered, and then after discovery, it can be manually registered in the network control application.

AJA NMOS is not installed by default ("complete") and should instead be selected through the "custom" dialog if desired.

Once installed AJA NMOS can be set to launch upon reboot or power up. The applications function is to make the KONA IP discoverable and controllable by various IP routing and control systems (e.g Imagine, LAWO, Sony). Discovery, registration and network control are not part of SMPTE ST 2110 but are specified by JT-NM NMOS or Network Media Open Specification. Two parts of this standard are IS-04 Discovery and Registration and IS-05 Connection Management.

When the tray icon is clicked (on the Mac or right click on Windows), the AJA NMOS application offers a number of options:

- View Log - toggles opening or closing of the log window
- Stop/Start Service - allows the NMOS service to be stopped and restarted without quitting the application
- Enable/Disable Debug Log - enables or disables the generation of debug output to the AjaLogger and the log window
- Enable/Disable DNS Debug - enables or disables additional DNS debug information (independent of Debug Log setting)
- Enable/Disable Verbose Debug - enables or disables additional debug information if the Debug Log setting is enabled
- Select Interface - NMOS only uses one interface to access the registry. If there is only one interface, then that is not a problem. If there is more than one, then if auto is selected, it will automatically choose one based on whether it sees any mDNS messages on one of the interfaces. Otherwise, the interface can be selected.
- Set Registry IP - allows the registry ip address and port to be set manually.
- Quit - causes the NMOS application to exit"

## AJA Software & Utilities

---

AJA's KONA software and hardware were developed for powerful integrated video/audio capture, editing, and production with a variety of 3rd-party software. With KONA and a qualified computer, you have the ultimate system for production, post-production, broadcast, and streaming work. AJA software is distributed as a unified package which includes all the software, firmware, plugins, and utility programs for AJA's Io, KONA, and T-TAP products.

Four retail packages are available, one for Mac, one for Windows, and two for Linux (one package for Ubuntu, one package for Red Hat/CentOS).

*NOTE: Support for the Linux OS retail drivers is based on the Linux application used and comes from the application's vendor.*

To download AJA software, go to the AJA website:

<https://www.aja.com/en/support/downloads>

For a complete software compatibility list, see the AJA website link:

<https://www.aja.com/en/category/edit/compatibility>

Frequently Asked Question documents for various AJA products are available at:

<https://www.aja.com/products/kona-ip#support>

## Mac, Windows and Linux Packages

---

These packages include:

### Drivers

---

AJA device drivers for tightly integrated hardware/software operation.

### AJA Control Panel

---

The Control Panel provides:

- Source selection and control of your AJA hardware
- A block diagram showing the signal routing and processing being performed

### AJA Control Room

---

Control Room is a cross-platform software application for ingest, playback and output with AJA devices.

### AJA System Test

---

System Test provides accurate and detailed evaluations of drive and system performance statistics, allowing you to measure the capabilities of your system for recording and playing back various resolutions and codecs. The application includes:

- System Disk Test
- AJA Device Test
- System Report

The application tests Read and Write, Capture and Playback speeds in both Megabytes per second and Frames per second. The disk speed tests differ from standard disk I/O performance applications in that they specifically test the system under conditions typically encountered with video capture, playback, and editing.

*NOTE: Theoretically the best test is to fill your storage disk to 80% and then test capture at the highest data rate you will use.*

*NOTE: For the most accurate System Disk Test results for 4K or UltraHD resolution, set the Test File Size to 16Gb.*

### AJA NMOS App

---

Available for discovery, registration and control via an NMOS compatible control system. NMOS enables the widest possible interoperability for Video over IP control systems.

## Additional with Mac and Windows Packages

---

### 3rd-Party Plugins

---

AJA provided plugins for popular 3rd-party Professional Video Applications from Adobe, Avid, Apple, Telestream, and others.

## Network Requirements

---

For uncompressed workflows (SMPTE ST 2022-6 and SMPTE ST 2110) a 10GbE switch is required.

For SMPTE ST 2110 specifically, a PTP clock source must also be deployed and the switch must therefore also be PTP aware.

In all cases the switch used must be both managed (configurable) and IGMP aware.

SFPs are not included with the purchase of KONA IP. Recommended SFPs are listed in "[Specifications](#)" on page 64.

## LLDP

---

LLDP (Link Layer Discovery Protocol) is supported with KONA IP. The Chassis ID and the Port ID of the first switch encountered upstream in the path from KONA IP to the network will be displayed in Control Panel within the LLDP Chassis ID field and LLDP Port ID field. The first upstream switch, in turn, displays the LLDP information (Chassis ID and Port ID) of the downstream KONA IP.

## System Requirements

---

*NOTE: Beginning with version 16.1, on macOS, the KONA IP supports Apple's M1 chip, as well as earlier Intel processors.*

AJA Video recommends that your system meet minimum hardware and software requirements to achieve a satisfactory level of performance. Updates to system requirements are subject to change.

*NOTE: See Software Vendor system requirements for GPU recommendations and additional hardware requirements and recommendations.*

See the KONA IP Release Notes, available on the AJA website and also installed with the software package, for detailed system requirements including OS, CPU, RAM, and GPU.

For IP installations specifically, AJA recommends:

- IP infrastructure with adequate bandwidth to sustain the capture and playback of the material you expect to be working with across the number of systems that are active at any given time
- For multi-seat installations, IP infrastructure that is comprised of fully managed switches and is in turn supported by a team of qualified network administrators
- For SMPTE ST 2022-7 implementations, two entirely independent network infrastructures are required for true redundancy

*NOTE: For large scale installations with shared storage, IP, or for very high performance requirements, AJA recommends consultation with an experienced a system integrator. A consultant will be able to assist with many important variables.*

## Disk Storage Methods

---

To ensure performance and quality, the disk storage system used with the workstation must be able to meet the demands of storing real-time uncompressed media. At the very minimum, the disk storage system must be able to provide and maintain a consistent transfer rate from the workstation to disk (read/write). There are a variety of system configurations and peripherals that can provide this level of performance.

For more on disk storage performance see "[AJA System Test Application](#)" on page 13.

# KONA IP Features

---

KONA IP is designed as a flexible platform for supporting various different IP standards and types:

- SMPTE ST 2110 uncompressed HD video over IP, including Transmit support for 2022-7, thus providing for playout redundancy.
- SMPTE ST 2022-6 uncompressed HD video over IP including support for 2022-7 Transmit and Receive.
- KONA IP can also be configured to use all streams for input or output, thus supporting up to 4K p60 uncompressed transport via ST 2110-23 (in this case 2022-7 support is not available).

*NOTE: NDI is supported on KONA IP in the same way as it is supported on KONA 4, courtesy of running Newtek Connect.*

KONA IP supports different operating modes for different needs. By loading a different version of firmware, you can tune your AJA hardware to the requirements of the task at hand.

## Video Formats

---

See "[Appendix A Specifications](#)" for a listing of supported video formats.

## Physical Connection for IP Video

---

- 2 x 10 GigE Ethernet SFP+ Cages - SFP+ modules (not included).

See "[Appendix A Specifications](#)" for a list of SFPs tested by AJA.

## Inputs and Outputs

---

- AJA Desktop Software package configured by default for ST 2022-6 operation with two simultaneous uncompressed streams on the top SFP (one In, one Out).
- For ST 2022-7 operation, a second SFP is used for redundant transport of the other SFP's signals.
- When supporting 4K with KONA IP via ST 2110-23, note that both SFPs are being used in one direction, either input or output.
- KONA IP HDMI output supports HDR signaling and monitoring for HDR10 and HLG. HLG support is application dependent. Check with your software manufacturer for compatibility.

## Digital Audio Input

---

- 16-Channel embedded audio

## Digital Audio Output

---

- 16-Channel embedded audio, 16- and 24-bit per channel, 48 kHz sample rate, synchronous
- 8-Channel HDMI embedded audio, 48 kHz sample rate, synchronous

## Signal Timing

---

- 1x BNC assignable to reference video or LTC input
- Relevant to SMPTE ST 2022-6 workflows only
- Not used for SMPTE ST 2110 workflows

---

## Internal HD/SD Hardware Downstream Keyer

---

KONA IP provides a powerful hardware keyer that can place graphic files with an alpha channel over video in a selectable matte or the contents of the card's framebuffer from a software application (including AJA TV). Key a bug or text over picture and avoid what might normally be a lengthy software render. Also, working with these software applications, you can key video that has an alpha-channel over video input or a matte. For example, you can load a QuickTime clip that has an alpha-channel (a flying logo generated in the Animation codec) into AJA TV and then place it over live video coming into the card and then passing both on to a VTR for recording or broadcast.

---

## ANC Support

---

KONA IP can transmit and receive ancillary data (timecode, closed captioning, custom payload) in both SMPTE 2022-6 and 2110-40 modes of operation.

---

## KONA IP Connectors

---

---

### SFP Cages and Modules

---

Two SFP+ cages are provided to connect two separate 10 GigE Ethernet Links. Both links can be bi-directional. Inputs and outputs for most uses will be set up over the same link if bandwidth allows it.

*NOTE: When using ST 2110-23, SFPs are no longer bidirectional and 2022-7 is not supported.*

*IMPORTANT: Only fiber SFPs are supported. Copper SFPs and / or emSFPs draw too much power and may cause damage and / or operating instability.*

---

### HDMI Output

---

A full-size HDMI connector on the KONA IP endplate provides HDMI 1.4b output. HDMI output also supports HDR 10 and HLG, plus multi-channel embedded audio (8 channels). HDCP is not supported on the output.

---

### Reference Clock

---

Methods of providing a reference clock for Video over IP domains depend on the SMPTE standard in use.

When using ST 2022-6, KONA IP can lock to analog black-burst or tri-level input, or the incoming SMPTE ST 2022-6 stream. For analog reference, a single BNC on the KONA IP endplate allows you to synchronize KONA outputs to your house analog reference video signal (or black burst). If you have a sync generator or central piece of video equipment to use for synchronizing other video equipment in your studio, connect its analog composite output here. When KONA outputs video in SMPTE ST 2022-6 mode, it locks to this reference signal. When connecting a reference video source, the locking signal should be the same format as the Primary format selected in KONA software. It is possible in some circumstances to use an alternate format video signal if the basic frame rate is compatible.

With ST 2110, PTP (Precision Time Protocol) is recommended, but KONA IP can also lock to an incoming SMPTE ST 2110 stream, or it can free run.

---

## In This Manual

---

Chapter 1 - Introduces the product briefly, listing features and system requirements.

Chapter 2 - Provides complete instructions for installing and configuring the product.

Chapter 3 - Discusses operational aspects and how to work with 3rd-party software.

Appendix A - Lists answers to frequently asked questions.

Appendix B - Presents a list of technical specifications for the product.

Appendix C - Offers advanced ST 2110 Configuration information.

Appendix D - Provides important Safety and Compliance information.

# Chapter 2 – Installation

---

## Installation Overview

---

The installation and set up of a KONA card is simple, and may vary slightly depending on your system.

For the most up-to-date Mac system requirements for KONA, see the following AJA website:

<https://www.aja.com/en/support/kona-system-configuration/>

For the most up-to-date Windows system requirements for KONA, see the following AJA website:

<https://www.aja.com/en/support/kona-pc-system-configuration/>

## AJA System Test Application

---

AJA System Test is a utility for measuring system performance with AJA KONA Video Capture cards. It is installed with the KONA Driver. The application includes:

- System Disk Test
- AJA Device Test
- Disk + Device Test
- System Report

The application tests Read and Write, Capture and Playback speeds tests in both Megabytes per second and Frames per second. The disk speed tests differ from standard disk I/O performance applications in that they specifically test the system under conditions typically encountered with video capture, playback, and editing.

The theoretical best test would be to fill your storage disk to 80% and then test capture at the highest data rate you will use, since this is the slowest your storage subsystem will run while still having some capacity for capture.

## Unpacking

---

### Shipping Box Contents

---

Your KONA shipment includes:

- KONA IP card

As you unpack your shipment, carefully examine the contents. Ensure you received everything and that nothing was damaged during shipping. If you find any damage, immediately notify the shipping service and supply them with a complete description of the damage. AJA will repair or replace damaged items. If you find shipping damage, contact your AJA dealer or distributor for details on how to have your KONA card repaired or replaced.

*NOTE: Save packing materials and the shipping box. If you ever require service or move your system use the packaging materials and box for safe shipment.*

# Installing the KONA Card

---

Figure 1. KONA IP Card



The KONA card can be installed into a PC chassis, legacy Mac Pro chassis with PCIe slots, or into a Thunderbolt PCIe external chassis.

1. Turn off power to the host chassis.
2. Touch the outside of the chassis to discharge any body static.
3. Remove the power cable from the back of the chassis.
4. Open the chassis.
5. Locate a recommended PCIe slot (see the AJA website for slot selection instructions).
6. Remove the backplate from the PCIe slot.
7. Touch the chassis to discharge any body static.
8. Remove the KONA card from its anti-static bag.
9. Carefully insert the card by rocking it slowly into the slot. Ensure the card aligns properly with the slot opening and is fully seated.
10. Secure the card in the chassis.
11. Close the chassis.
12. Power up the chassis.

*NOTE: Always put a RAID controller and KONA on separate PCIe busses. This improves performance by reducing bus contention.*

## Cabling the System

---

### KONA IP Cable Connections

---

For SMPTE ST 2110 and ST 2022-6 operation, 10 GigE infrastructure can be connected with either a short (3 feet) Direct Attached cable, or optical fiber cable with appropriate SFPs.

*NOTE: ST 2022-7 for ST2110 is supported for Transmit only. ST 2022-7 for 2022-6 is supported for Transmit and Receive.*

Figure 2. IP Configuration Example for ST 2110 Workflow

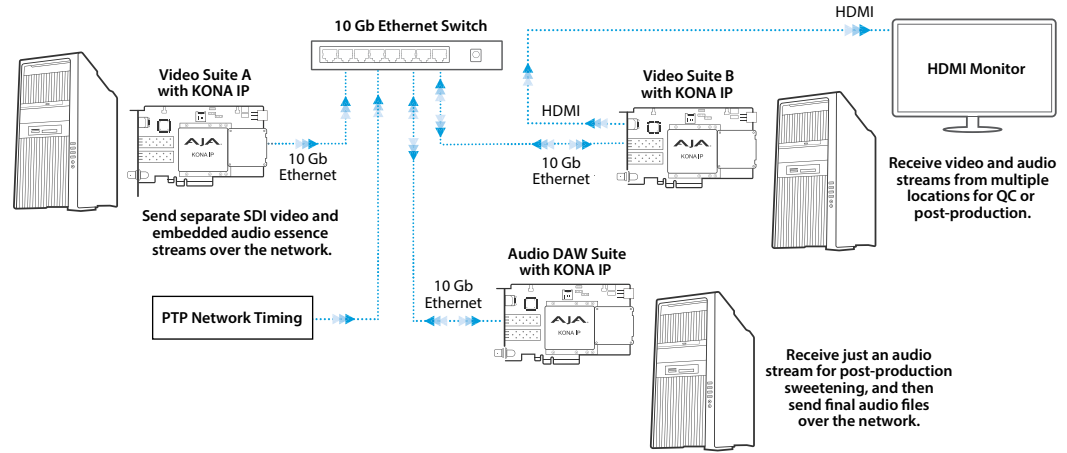

Figure 3. IP Configuration Example for ST 2022-6 Workflow

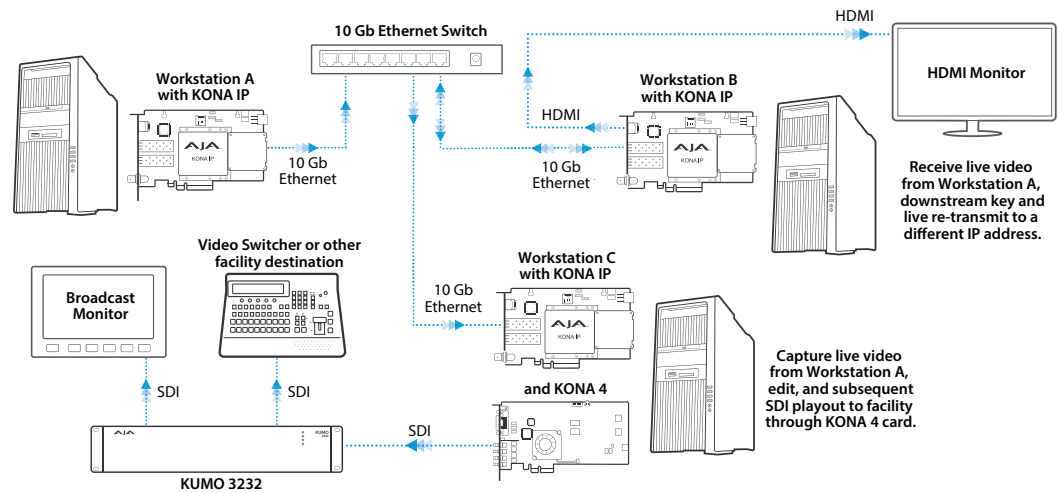

Figure 4. IP Configuration Example for ST 2022-7 Workflow

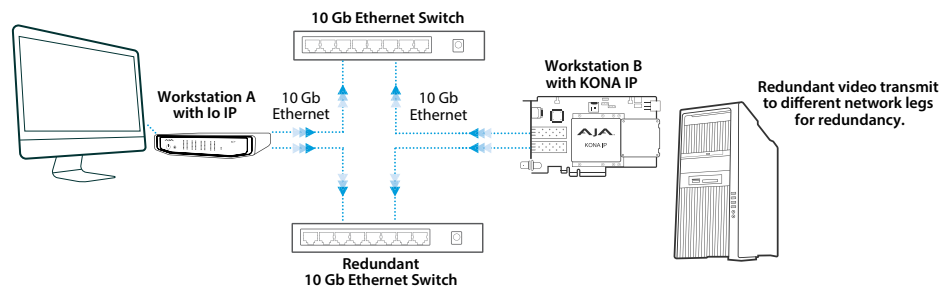
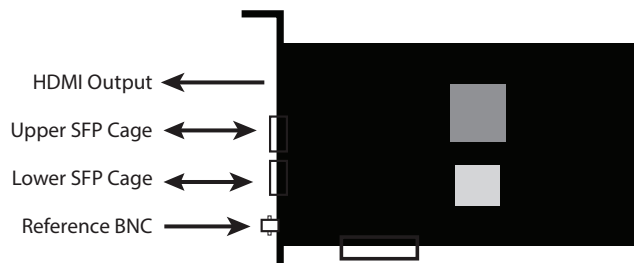

Figure 5. KONA IP Card Connections



The KONA IP card fits into a standard PCIe slot of a computer or into PCIe chassis. The end spine has a full size HDMI output connector, two SFP cages (Upper and Lower), and a reference BNC connector.

## SFP Modules

---

For SMPTE ST 2022-6 and ST 2110 operation, modules inserted into the two SFP+ cages can be used to connect two separate 10 GigE Ethernet Links.

With AJA Desktop Drivers, the Upper and Lower SFP modules are configured using AJA Control Panel software, using the Network and IP Settings tabs. In most cases, only the top SFP will be used, providing up to two total streams of SD or HD video, each with 16 audio channels and metadata, for simultaneous input or output, i.e. when using SMPTE ST 2022-6. Both links are bi-directional (one In, one Out). When using SMPTE ST 2022-7, the Lower SFP carries a duplicate of the Upper SFP data.

See "[Appendix A Specifications](#)" for a list of recommended SFP modules.

## Inserting and Removing KONA IP Cards

---

SFP modules must be removed from the KONA IP card before the card can be inserted or removed from the host. Disconnect the LAN cables, if necessary, and then lift the lever to unlock the SFP module for removal.

*NOTE: When switching between workflows, you will have to load the correct bit file and go back through your network setup on the card to ensure a successful "mode swap".*

# Installing KONA Software

---

For AJA KONA software installation, go to the downloads page on the AJA website:

<https://www.aja.com/en/support/downloads>

Always uninstall previous versions of KONA software before updating your software. Before installing the KONA software package, ensure that your capture/editing application is installed as detailed in its user documentation. You cannot use KONA with a third-party application until the application has been installed and run at least once on your workstation. Next, install the KONA software package.

## NMOS Installation

---

KONA IP supports NMOS (Networked Media Open Specifications), using a stand-alone AJA NMOS application. The AJA Installer does not install the AJA NMOS application by default. You must select NMOS using the "Custom" option during installation, and to enable this feature you will also need to manually launch this application and be connected to a network that has a running NMOS control application.

*NOTE: If you do not install AJA NMOS on your computer, NMOS control systems will not be able to register or control KONA IP.*

## macOS Installations

---

macOS High Sierra (10.13), macOS Mojave (10.14), macOS Catalina (10.15) and macOS Big Sur (11.x) all have security requirements that may present dialogs during installation. Please refer to the Release Notes for guidance.

## Types of KONA IP Firmware

AJA Desktop Software can provide the KONA IP with three different personalities, or modes of operation.

- SMPTE ST 2022-6 operation (s2022) uses the KonaIP s2022 firmware bitfile
- SMPTE ST 2110 operation (s2110) uses the KonaIP s2110 firmware bitfile

Switching between these different KONA IP operating modes requires loading the appropriate firmware bitfile as listed above.

By default, newly purchased KONA IP hardware will come pre loaded with ST 2022 firmware. Loading the s2110 bitfile will provide that functionality.

## Unicast and Multicast Support

KONA IP supports both unicast and multicast operation. Unicast operation is point to point, from one sender to one receiver. Multicast operation is from one sender to possibly multiple receivers. In both cases, the sender transmits information to a location (IP address) on the network, and receivers access that information over the network using that location IP address. Compatible IP addresses are required for each type of operation. These network settings filter the IP addresses so the information is sent successfully to the desired receiver(s).

*IMPORTANT: Proper network configuration settings vary, depending on your particular network environment. Because the process can be complicated, you should always consult with your facility's IP or Networking Engineering department before configuring KONA IP network settings.*

Listed below are example sets of compatible IP addresses that could be used in an isolated network to test KONA network operation.

*Table 1. Example Compatible Unicast IP Addresses*

Control Panel Screen	Parameter	KONA IP 1 (send)	KONA IP 2 (receiver)
IP Network	Local IP Address	192.168.10.31	192.168.10.32
	Subnet Mask	255.255.255.0	255.255.255.0
IP Input	Destination IP Address	---	192.168.10.41
	Destination Port	---	2000
IP Output	Destination IP Address	192.168.10.41	---
	Destination Port	2000	---

*Table 2. Example Compatible Multicast IP Addresses*

Control Panel Screen	Parameter	KONA IP 1 (send)	KONA IP 2 (receiver 1)	KONA IP 3 (receiver 2)
IP Network	Local IP Address	192.168.10.31	192.168.10.32	192.168.10.33
	Subnet Mask	255.255.255.0	255.255.255.0	255.255.255.0
IP Input	Destination IP Address	---	239.0.61.100	239.0.61.100
	Destination Port	---	10000	10000
IP Output	Destination IP Address	239.0.61.100	---	---
	Destination Port	10000	---	---

# Chapter 3 – Operation

---

## Using KONA with Professional Video /Audio Software

---

After you install the AJA software package on your computer, you're ready to begin capturing and playing back video and audio using your choice of third-party software. You can go here for AJA software and documentation:

<https://www.aja.com/en/support/downloads>

For further support information and downloads for third-party software, go to:

<https://www.aja.com/en/category/edit/compatibility>

Frequently Asked Question documents for various AJA products are available at:

<https://www.aja.com/products/kona-ip#support>

## Capture Formats

---

When capturing, you can record data in the following file formats:

- DPX
- TGA
- BMP
- QuickTime
- MXF

*NOTE: Support by KONA IP of QuickTime for Windows has been discontinued. Instead, AJA supports ProRes family capture and playback for macOS, Windows and Linux via AJA Control Room.*

*NOTE: Other file types can be captured using third-party capture applications such as Sienna, Softron, Tools on Air, Drastic Technologies, or Quadrus.*

## AJA Control Panel Overview

---

The AJA Control Panel is a software application that provides a simple visual showing how the KONA IP hardware is currently configured and allows you to make changes. You can change signal input and output parameters and define the video processing that will be performed.

The AJA software installer automatically installs the Control Panel application on your computer.

## AJA Control Panel Operating Modes

---

AJA Control Panel has two fundamental operating modes.

**Playback Mode** - Used for playing back video files from the computer, usually with a non-linear editing application (NLE) or AJA Control Room, through the KONA card to that card's video/audio outputs for viewing and/or external recording.

**Capture Mode** - Used for capturing video/audio signals that are coming into the KONA card from an external source to create video files on the computer using AJA Control Room or an NLE, or just for display on the KONA outputs. This mode is also used for stand-alone video display or conversion when Control Panel is being used without an external controlling application.

## AJA Control Panel User Interface

The AJA Control Panel user interface includes a visual block diagram of the unit's current configuration. The current status, input and output settings, and many other details are depicted in the color-coded block diagram. Below this block diagram are various controls for changing operating parameters, which will vary depending on which function screen has been selected.

**NOTE:** AJA devices can automatically adjust settings for specific signal inputs, outputs, and processing. This information is reported on the AJA Control Panel's block diagram. One example is if outputting 4K, HFR, YCbCr 4:2:2 10-bit from the framebuffer, if the HDMI transmitter is version 1.4b the video is automatically adjusted to 4:2:0 8-bit (e.g. KONA 4, KONA IP).

The left side of the AJA Control Panel provides a navigation list of available function screens. Clicking on a link (or alternatively, a related element in the block diagram) displays a function screen corresponding to that topic.

**NOTE:** Although KONA IP is sending and receiving video over IP, once that data is decoded to memory it is governed by the same video menus used for SDI and HDMI based AJA I/O solutions.

Figure 6. AJA Control Panel, Block Diagram and Controls

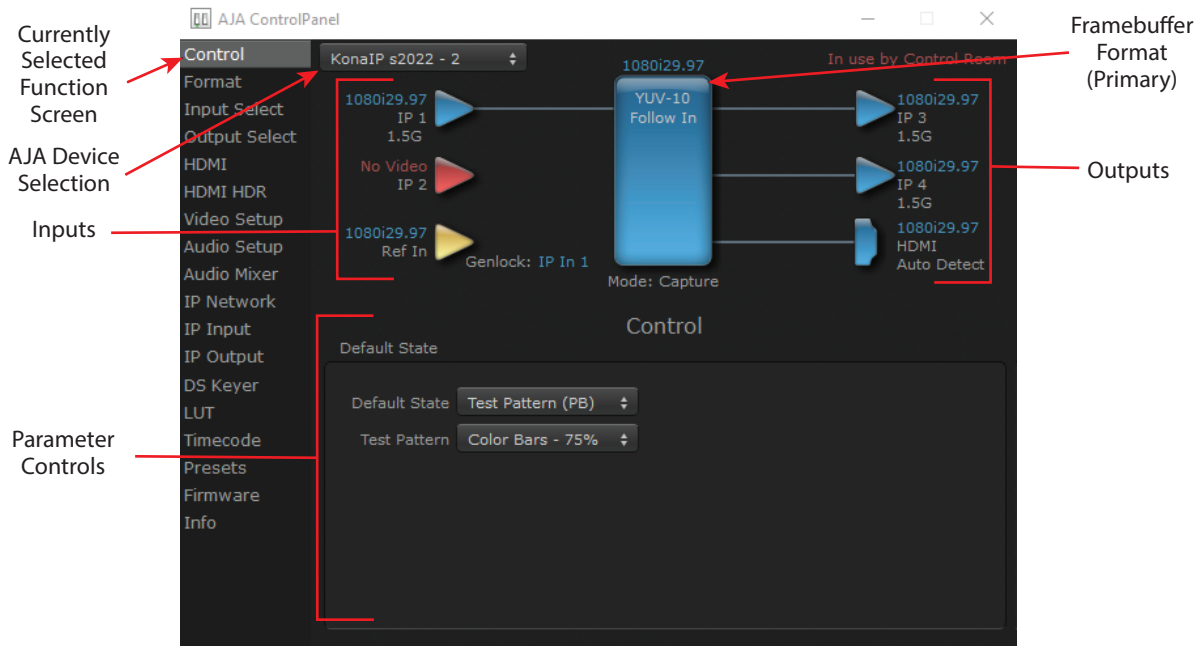

## Block Diagram Area

The top block diagram area of the Control Panel screen is a visual representation of the processing, if any, that's currently occurring, including inputs/outputs, reference source, and system status. Lines between inputs, the framebuffer, and outputs, show a video path. Where there are no lines, there is no connection; this can be because an input or output isn't selected in the Input Select menu. The lines will also show whether the outputs are video or video + key.

You can click any of the function screen selection links in the left column to view its current settings or click on an icon to call up its related settings screen. You can also right-click or Control-click to see context-sensitive information and choices.

Figure 7. Context Sensitive Menu

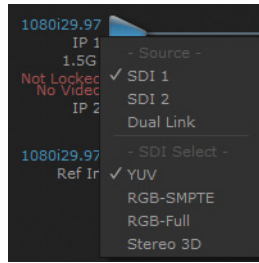

## Color Meanings

All items in the AJA Control Panel block diagram are color-coded to show what is happening in real time. This applies to both icons and text. These colors indicate:

**Blue** - Video is same format as the Primary Format (framebuffer)

**Yellow** - Reference video (black burst or other reference source)

**Red** - The selected operation cannot be performed

## Input/Output Icons

The input and output icons are triangles that together with their color show all the input and outputs and their status (selected, not selected, input present or not, format, etc.). A complete video path is shown when inputs and outputs are connected with lines going to/from the framebuffer.

Figure 8. Input/Output Icons

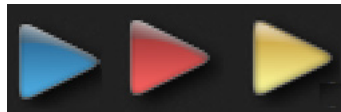

*NOTE: Hovering your cursor over an Input or Output icon opens a tooltip that reports that connector's signal status (Input signal detected, Output signal enabled, Input or Output disabled).*

## Framebuffer

The framebuffer is the “engine” where your third-party applications interface with the AJA device. The framebuffer has a format (called the “Primary Format”) and color space that it follows, as defined in the linked menu screens or via external application software.

## Device Format

The Device Format is the media format written to disk and used in your project. This is the format that the framebuffer will use and is shown in the Control Panel using the color blue. It is the format that the third-party application software will either receive from the AJA hardware, or is sending to the hardware. All icons in blue are the same as the Device Format used by the framebuffer. Also any text descriptions in the block diagram that appear in blue indicate that something is in the Device Format. For example:

- If the input and output icons are blue, you know that the same format is used throughout the video path. No format conversion is being performed.
- If the input or output icon colors differ (blue input and green output icons for example), you know that a format conversion is being performed.

## Controlling Application

It is important to understand that the computer can contain many applications that can use the AJA device (as you switch from window to window) and it may not always be obvious which currently controls it.

*Figure 9. Control Panel In Use Message (in red)*

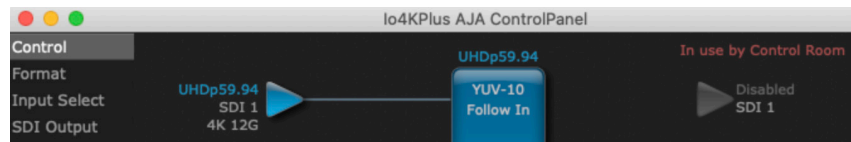

In the top right corner, the Control Panel displays the name of the application controlling the unit. In some cases, applications may not always properly “let go” of the I/O interface as another takes over—you’ll be able to tell by looking at the Control Panel.

## Controlling Application Format Selection

If a running controlling application uses KONA IP for capture or output, it controls the Device Format via its own menus and settings. For example, when the Third-party editing application is active (it’s the front-most application) and has KONA IP as its “A/V Device”, the KONA IP’s Device Format is determined by the application’s “Video Playback” settings. These format selections are reported in the AJA Control Panel block diagram.

Controlling applications can start and stop and change modes—even while they are running. And the behavior of different controlling applications can vary: some applications take control of the interface as soon as they are launched and don’t give it up until they quit, while other applications take control of the interface only when they are the “front-most” running application and then relinquish control when they’re not. Even these controlling applications may not relinquish control until capture or output operations are completed.

## AJA Control Panel Restart Services

AJA Control Panel Restart Services is new functionality (since v6.1) that allows for restarting the AJA services if necessary. This can help if various applications begin contesting for access to the Video I/O device. In this situation an **AJA Agent is not running** message can appear as the controlling application status. Hovering your cursor over that message displays a **Restart Agent** button, which clicking on will bring Control Panel back to its startup state. Then an application can freshly acquire control of the I/O device. Currently this feature is only available for macOS installations.

*Figure 10. Restart Services Popup Message*

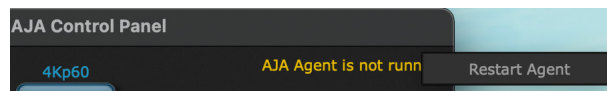

## Control Recommendations

---

We recommend you have the Control Panel running and visible at all times. When the Control Panel is running in the background (not front-most) you can see what the interface is doing and who has control of it.

## Presets

---

Setups can be named and saved as a snapshot (Preset) for recall at any time. You can save various AJA device Control Panel configurations associated with your frequent tasks. You don't have to spend time resetting interface configurations, just load the previously saved Preset for each task. See "[Saving, Loading and Deleting Presets](#)" on page 50 for more information.

If you work on multiple systems and want to carry your saved setups to another location, you can copy your saved Preset files on to movable storage and load them into any computer running the AJA Control Panel application.

### Mac OS Preset Files Storage Location

---

- From the Finder, hold down the Option key (to display the Library directory) and click on Go/Library/Application Support/AJA/<device name>/Presets/

### Windows Preset Files Storage Location

---

- c:\Users\<username>\AppData\Local\AJA\Control Panel\<device name>\Presets\

*NOTE: When you visually browse to the above location, depending on Windows OS setting you may not be able to visually see the folder referred to in the path. Instead, you have to fill out the rest of the Windows path manually (i.e. type the rest of the address in the navigation bar when you hit the "end" of the browsing path).*

## Default Preferences

---

When an AJA device starts up, a preference can determine what settings it will have it when it begins to operate. The AJA Control Panel offers two default preference settings:

- Local Preference - A preference stored from the last AJA device's Control Panel settings to be used on next startup of AJA Control Panel. This occurs on next restoration of the default state (triggered by start up of host CPU, startup of the AJA device, or when a third-party application releases the AJA device).
- Global Preference - A preference saved for use as a global default start state for an AJA device that can be shared by multiple users, applied on first startup, or by pressing the Control Panel **Reset Device...** button.

## Local Preference

---

The Local Preference file (com.aja.devicesettings) exists to immediately and automatically store all parameter changes made by a user on a particular AJA device. When any control is changed in the Control Panel, that change is recorded in the Local Preference file stored in a unique location on that computer that is dedicated to that particular device, serial number, and logged-in user. Then, when AJA Control Panel is restarted for any reason, the AJA device being controlled restores the settings being used when Control Panel was last closed.

The Local Preference file can be accessed at the following locations.

On Mac:

- From the Finder, hold down the Option key (to display the Library directory) and click on Go/Library/Preferences/com.aja.devicesettings.

On Windows:

- C:\Users\<USER\_NAME>\AppData\Local\aja\com.aja.devicesettings

*NOTE: Clicking on the AJA Control Panel "Erase All Prefs" button deletes the existing Local Preference file from this location. This file will be recreated as soon as any Control Panel setting is changed.*

*NOTE: Clicking on the AJA Control Panel "Reset Device..." button will delete the existing Local Preference file. If a Global Preference file is found, these settings are reloaded. If a Global Preference file is not found, "factory defaults" are loaded and the device is set to that state*

## Global Preference

---

An administrator can establish a house standard for an AJA device by copying a preference file to a shared computer location. Once placed at that location, it becomes a Global Preference file where it will establish a standard default startup state for all users of that AJA device using that computer system. These settings preempt the initial AJA factory default settings, and are applied when an AJA device is first powered up, or when the Control Panel **Reset Device** button is pressed.

To establish a Global Preference, the administrator first configures the AJA device (which automatically creates a "com.aja.devicesettings" Local Preference file in the location identified above) and then copy or move that file to the correct computer locations (manually or by pushing it out across the network) on all the computers that use the AJA device.

*NOTE: If the user makes changes to an AJA Device's Control Panel settings, those changes are saved to the Local Preference file, which will take priority over the Global Preference file.*

The shared computer locations for a Global Preference file are:

On Mac:

- From the Finder, click on Go/Computer/<System HD>/Users/Shared/AJA/ and copy or move the "com.aja.devicesettings file" described above to this location.

*NOTE: The "AJA" folder needs to be created manually at this location before moving the preference file into it.*

On Windows there are three possible shared locations depending on your system:

- C:\Users\Public\Aja\
- C:\Users\All Users\Aja\
- C:\ProgramData\Aja\

Copy or move the "com.aja.devicesettings file" described above to one of these locations.

*NOTE: The AJA Control Panel Info screen displays the path to the Global Preference file on that computer.*

*NOTE: Clicking on the AJA Control Panel Erase All Prefs button does NOT delete an existing Global Preference file from this location.*

## Using Multiple AJA Devices

More than one AJA device can be used with your host computer. Using AJA Control Panel, you can choose which installed AJA device an application uses. If you have more than one device installed, you will see a device name in a pulldown menu on the upper left of the screen. To “target” a specific installed device for use, click on the text and select from the list in the pulldown.

Figure 11. Control Panel Screen Showing Multiple AJA Devices

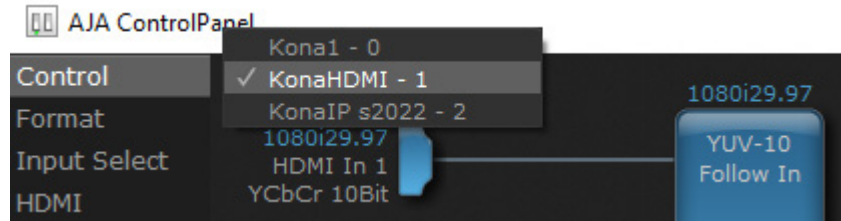

When you launch an application, the application will use the device that is currently selected in AJA Control Panel. When an application is running, you can change the “targeted” device with the pulldown menu. The running application will retain its connection to the previously selected device. If you change the “targeted” device and then launch a different application, that application will use the new device, while the first application you launched will continue to use the other AJA device.

Performance of multi-device use depends on a variety of factors: CPU usage, RAM, disk IOPS/ bandwidth for streams of video, etc. and therefore performance may vary. Also be aware that multiple input/output streams are only supported by software that is explicitly designed for a multi-device environment.

## Multiple AJA Product Performance

Performance of multi-product use depends on a variety of factors: CPU usage, RAM, disk IOPS/ bandwidth for streams of video, etc. and therefore performance may vary. Also be aware that multiple input/output streams are only supported by software that is explicitly designed for a multi-product environment.

## Function Screens

Listed below are the function screens for KONA IP and what they are used for.

Table 3. KONA IP Function Screens

Screen	Functions
Control	Configure some basic KONA IP operation options and output timing.
Format	Select the framebuffer Device format.
Input Select	View and edit input selections and audio mapping.
Output Select	Select output format.
HDMI	Configure the HDMI
HDR	Configure High Dynamic Range settings output
Video Setup	Configure Video such as composite black level, progressive format and ancillary data (Closed Caption) option.
Audio Setup	Configures Audio options such as analog audio monitor level.
Audio Mixer	Select and mix audio sources for playback and capture.
IP Network	Configure network parameters for the location of each KONA IP physical SFP cage.

Screen	Functions
IP Input	In ST 2022-6 mode, configure parameters for receiving inputs from the media network.
IP Output	In ST 2022-6 mode, configure parameters for sending outputs to the media network.
IP Config	In ST 2110 mode, configure parameters for network stream inputs outputs..
DS Keyer	Setup and control the insertion of keyed video from the frame buffer or graphics files with alpha channel.
LUT	Load a lookup table (LUT) file to adjust the calibration of color for any source.
Timecode	Monitors SMPTE 12M-2 timecode and configure timecode window burn output.
Presets	Add or delete saved preset configurations (handy for quick and easy recall of different KONA IP settings for varied workflows).
Firmware	Install firmware from your currently installed AJA software package.
Info	Display status information and the firmware version number. This information is generally intended for troubleshooting/support.

## About KONA IP Modal Operation

---

KONA IP cards support modal operation. Functionality depends on what firmware has been installed on that card. Different Control Panel screens are displayed, depending on the operating mode.

For KONA IP you can choose to install:

- KonaIP s2022—For use only with ST 2022-6 full bandwidth video, and supports use of two SFPs for up to four uncompressed HD streams.
- KonaIP ST 2110—For use only with full bandwidth video, supports use of two SFPs for up to four uncompressed HD streams, and permits transport of individual video or audio streams, or a set of multiple video and audio streams.

Most ST 2022-6 functionality is similar to ST 2110, with some exceptions. Refer to "[Control Panel Operation in ST 2110 Mode](#)" on page 52 for information about these differences.

# Control Panel Operation in ST 2022-6 Mode

## Control Screen

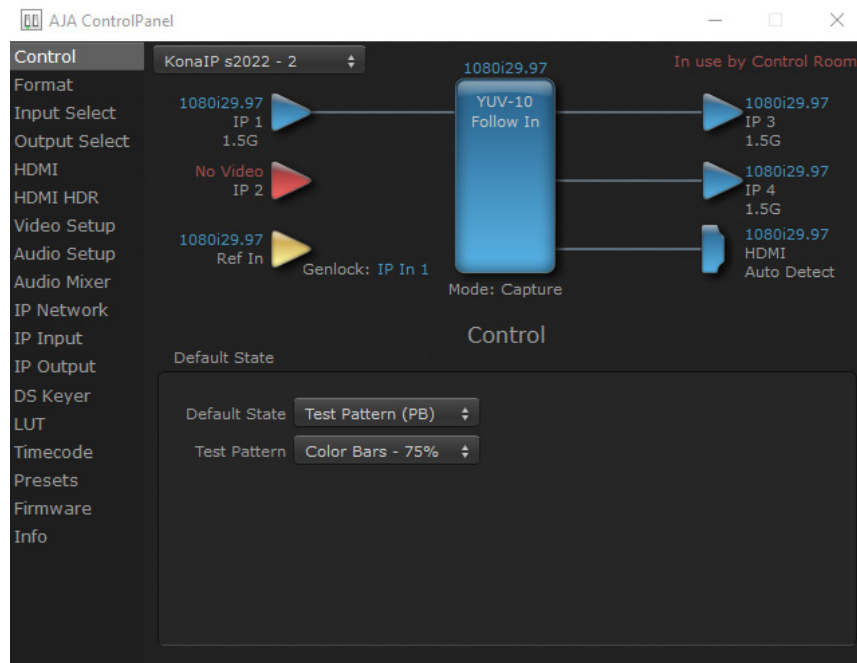

The KONA IP can be controlled by various software applications running on a host computer. The Control screen is where you select how the KONA IP directs video and is used by application software. This screen also provides control for configuring output timing with regard to external reference video and horizontal/vertical delay. The top of the Control Screen shows the currently selected AJA device if more than one is available in your system.

## Default State

This is where you select what the KONA IP will output as a default when no application has control of the board, such as when the Mac Finder or Windows Navigation Pane is active. Since KONA IP can be controlled by software applications as well as its own control panel, the output can change dynamically. When you select many video applications, they will take control of the KONA IP inputs and outputs. However, when an application that doesn't take control is active, these settings determine what KONA IP will output.

### Input Passthrough

This selection directs KONA IP to route video from its selected input through the device for processing and output.

## Test Pattern

---

This selection directs the KONA IP to output a choice of preset pattern when no other application is using the KONA IP. You can choose from:

- Black, Color Bars (75% or 100%), Ramp, Multiburst, Line Sweep, Multi Pattern, or Flat Field, Check Field, White, Border, Linear Ramp, Slant Ramp, Zone Plate, Color Quadrant, Color Quad Border, or 2SI Alignment (see below).

**2SI Alignment** - This test pattern consists of 1-pixel diagonal crosshairs plus a 3-pixel rectangle. If there is a misalignment, the diagonal crosshairs will not be a continuous line. If it is a top-bottom misalignment, the top and bottom of the square line will be broken, with white between them. If it is a left-right misalignment, the left and right lines of the square will be fuzzy or broken. This can easily be simulated by clicking the "Quad Swap" buttons in the control panel "Video Setup" tab.

- In addition to the preset test pattern choices, a "Load File..." selection at the bottom of the menu allows you to load any standard RGB graphics file (.tif, .psd, etc.) into the frame buffer for display.

While in Test Pattern mode, you can select RGB or YUV output via a pulldown menu.

*NOTE: The graphic file will not be scaled to fit. If it's smaller than the current frame buffer format, KONA IP will center it in the frame. If it's larger than the current frame buffer format, it will be cropped on the right and bottom. Also some graphics formats and bit depths may not be supported. Once a graphic file is loaded into the frame buffer it will be retained until it is overwritten by another graphic or test pattern, or when power is turned off. Graphic file names are only "remembered" in the menu until the AJA Control Panel application closed.*

## Hold Last App

---

This selection directs KONA IP to hold and output the last frame of video from the last application to control KONA IP. This can be helpful when operating in an environment where you're switching back and forth between multiple application windows.

## Format Screen

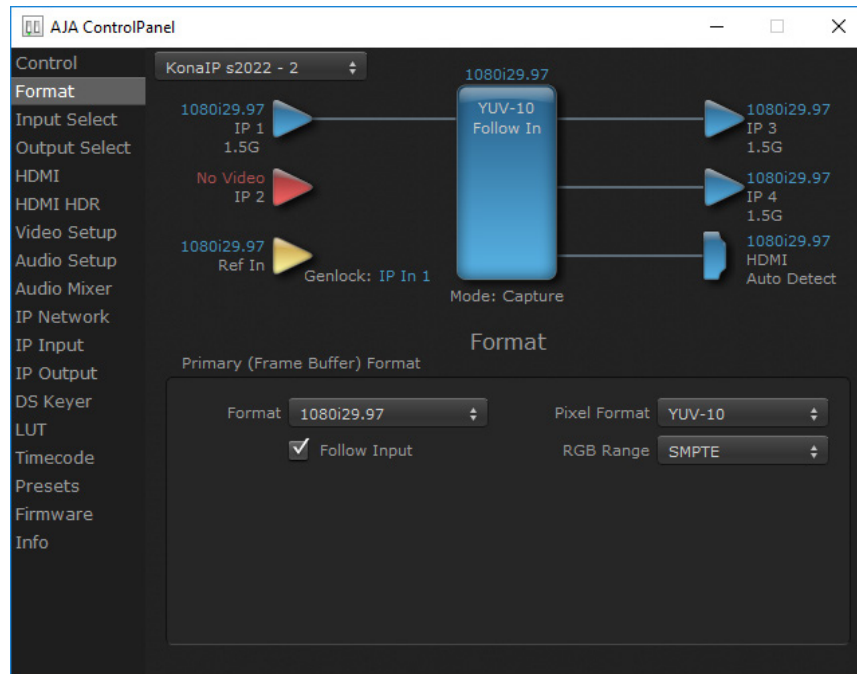

The Format Screen shows the video format currently in use by the KONA IP framebuffer (called the Primary Format) and allows you to change it. All throughout the Control Panel, choices are always presented based on what KONA IP can do with the signals available and the inputs/outputs selected.

*IMPORTANT: Do not confuse this Format function screen conversion, which uses AJA hardware and operates on either Mac or PC, with the separate Conversion function screen, which uses QuickTime for conversion and is only available on Mac.*

### Primary (Frame Buffer) Format

#### Format

This pull-down menu shows the currently selected format. When a change is made via the Video Format pull-down or by clicking an icon and selecting a new format via a contextual menu, the block diagram will change to reflect the new format.

*NOTE: The AJA Control Panel software uses the abbreviation "sf" instead of "PsF" when referring to "progressive segmented frame" formats.*

#### Pixel Format

Use this pulldown menu to choose: YUV-10, YUV-8, RGB-10, or ARGB-8 or RGB-12.

#### RGB Range

The RGB Range pulldown menu allows you to select either Full-range (0-1023) or SMPTE range (typically 64-940) for RGB color output.

## Follow Input

Enabling the Follow Input checkbox allows the Control Panel Buffer to auto-switch to whatever is the detected input format. This feature works only if the controlling application supports input-based capture—AJA Control Room for example.

**NOTE:** In ST 2110 mode, the Follow Input setting must be set correctly for proper operation. See ["AJA Control Panel ST 2110 Mode Follow Input Settings"](#) on page 53.

## Input Select Screen

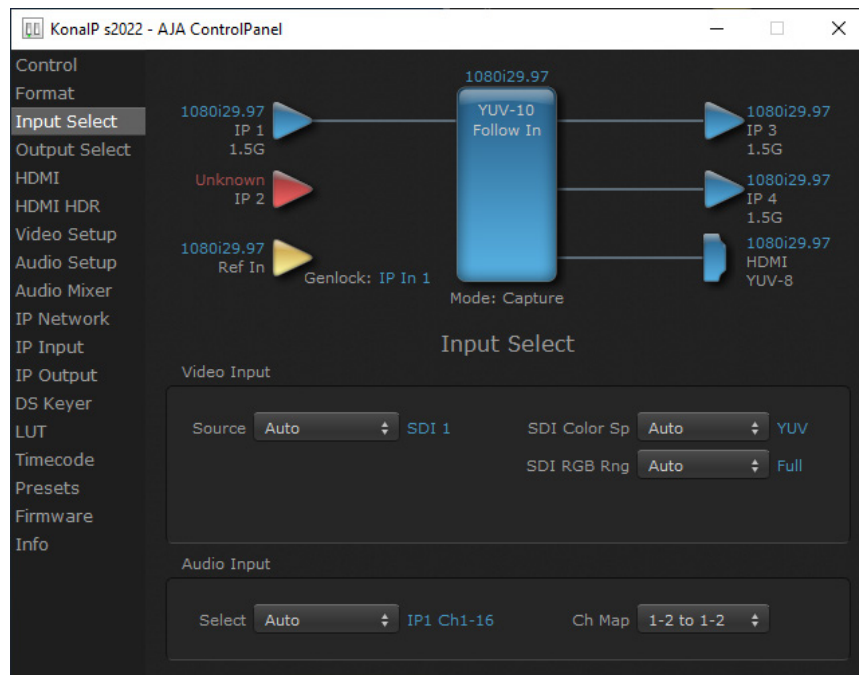

On the Input Select Screen, you can view the currently selected video and audio input sources and map audio sources to the channels supported by your editing application.

## Video Input

### Source

Select the Video Input source. Choose from IP 1 or IP 2.

### SDI Color Sp

Sets the color space. Select from Auto, YUV, or RGB.

### SDI RGB Rng

Sets the RGB range. Select from Auto, SMPTE, or Full.

## Audio Input

### Select

All 16 embedded audio channels (if present) are selected for input.

## Ch Map

If only two channels were selected in the third-party application you are using, you can select which two channels will be mapped to that application. Different Audio Input selections can have different channel mapping capabilities. Select from:

- 1-2 to 1-2
- 3-4 to 1-2
- 5-6 to 1-2
- 7-8 to 1-2
- 9-10 to 1-2
- 11-12 to 1-2
- 13-14 to 1-2
- 15-16 to 1-2

*NOTE: This setting does not affect the embedded audio being sent to the KONA IP's or output connectors.*

## Output Select Screen

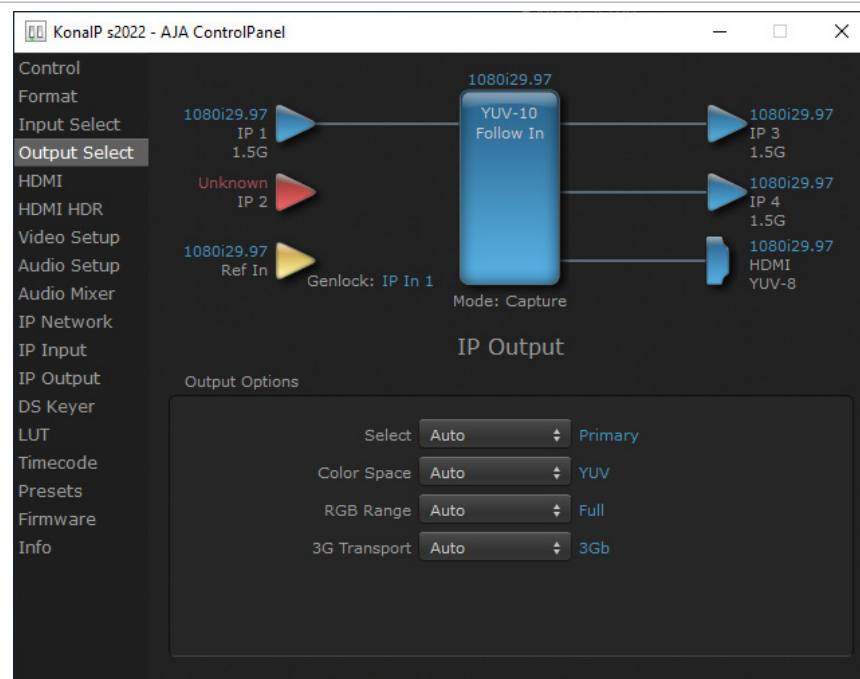

The Output Select Screen shows the current settings. Both IP outputs carry the same signal.

## Output Options

### Select

- Auto - Automatically selects the output format, based on the input or selected format.
- Primary - Selects the framebuffer format for output.
- Video+Key - When selected, this indicates that the IP Video 3 is set to the same format as the framebuffer. IP Video 4 is set to a video key signal associated with IP Video 3 (the shape to be cut out from the video - this will appear as a black and white image/matte). Using the second KONA output as an Alpha

Channel key, with the video output, may be useful for feeding production switchers, DVEs or other professional video equipment.

### Color Space

Sets the color space. Select from Auto, YUV, or RGB.

### RGB Range

Sets the RGB range. Select from Auto, SMPTE, or Full.

### 3G Transport

Sets the output transport. Select from:

- Auto - Automatically selects the transport, based on the input or selected format
- 3Gb
- 3Ga

## HDMI Screen

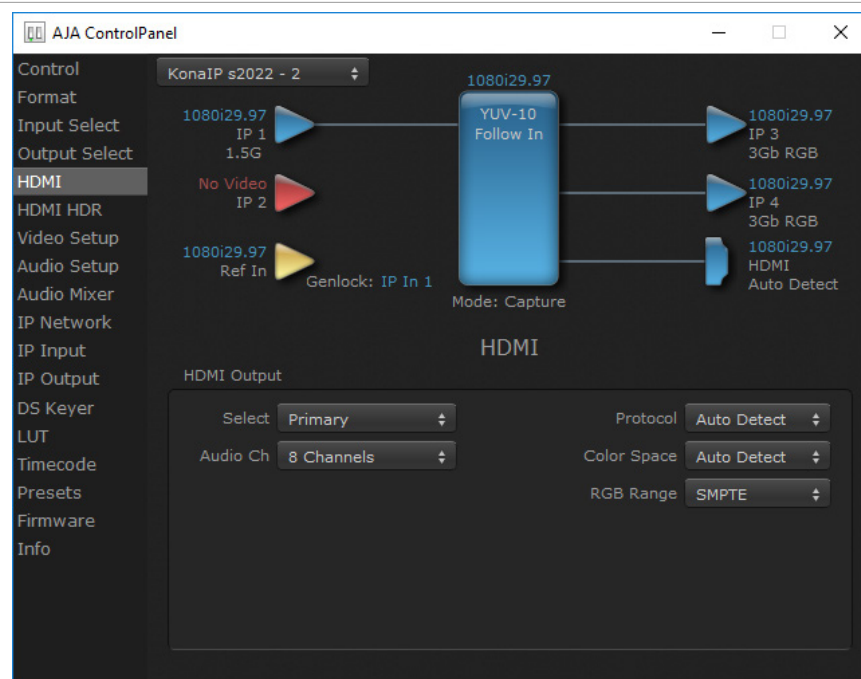

### Select Primary

The HDMI Output of the KONA IP is always the primary format. The current format and frame rate are displayed on the right.

### Audio Ch

An Audio Channel pulldown allows you to select the number of embedded audio channels for the HDMI output. Choose either 2 Channels or 8 Channels.

### Protocol

The Protocol pull down allows you to choose between two "Auto" modes, or to explicitly force the output to a desired protocol.

- Auto Detect - (most reliable) AJA device attempt to reconfigure the HDMI output to match the current protocol setting of the output monitor. This

option will be the most reliable in creating an output image. However, the output may result in loss of audio.

- Auto Set - (best quality) The AJA device HDMI out will attempt to automatically set the output monitor into the best protocol, usually HDMI.
- HDMI - Forces the use of the HDMI protocol regardless of the attached device's EDID. Connection may fail if output monitor does not support the HDMI protocol.
- DVI - Forces the use of the DVI protocol regardless of the attached device's EDID.

## Color Space

---

The Color Space pulldown allows you to choose between two "Auto" modes, or to explicitly force the output to a desired color space regardless of the attached device's EDID or user application needs.

- Auto Detect - (most reliable) AJA device attempt to reconfigure the HDMI output to match the current color space setting of the output monitor EDID. This option will be the most reliable in creating an output image. However, the output may result in an inferior image due to color space conversion and loss of bit depth.
- Auto Set - (best quality) The AJA device will attempt to automatically set the output monitor into the best color space and bit depth that matches the user's application needs regardless of EDID of the output monitor. This may result in loss of image if the output monitor does not support a specific color space mode.
- RGBA-8 - Forces the use of RGBA-8.
- RGB-10: Forces the use of RGB-10.
- RGB-12: Forces the use of RGB-12.
- YUV-8: Forces the use of YUV-8.
- YUV-10: Forces the use of YUV-1.

## RGB Range

---

The RGB Range pulldown menu allows you to select the type of RGB color output.

- SMPTE - (typically 64-940)
- Full - (0-1023)

# HDR Screen

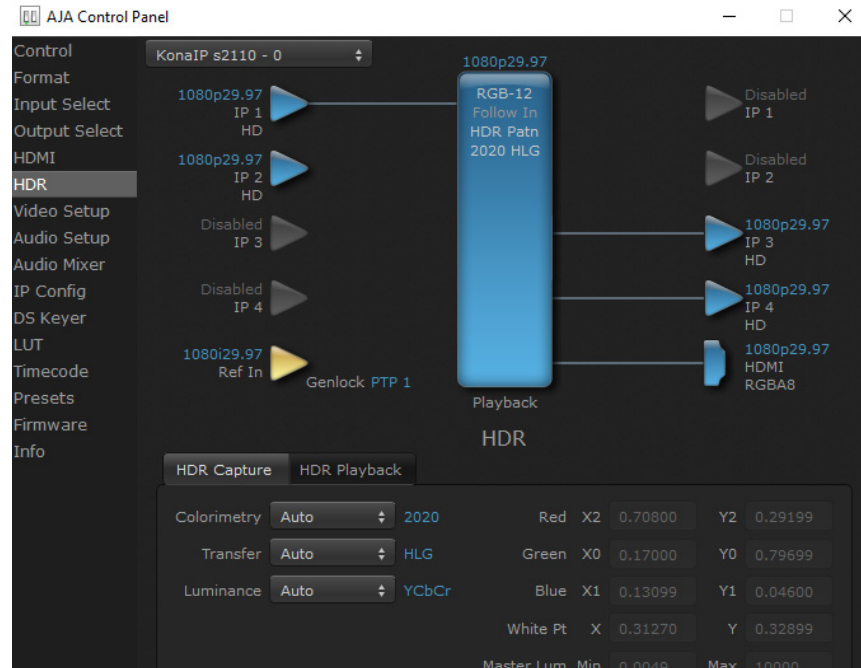

The HDR screen provides a sub tab setup for HDR playback via HDMI.

For HDMI destinations, side-band information is used to inform an HDMI sink device (such as a TV or monitor) that the video content is HDR. This includes generation of the Dynamic Range and Mastering Infoframe and the static metadata descriptors as defined in CTA-861.3 and HDMI v2.0a.

Included are preset primaries values for BT.2020 and DCI P3 color gamuts.

## HDR Capture Settings

### Colorimetry

- Auto - (default)
- SDR - Standard Dynamic Range
- P3 - P3 colorspace
- 2020 - BT.2020, typically used with HDR
- Custom - Allows custom values for the Digital Primaries.

### Transfer

The Electrical Optical Transfer Function metadata bit tells the HDMI display which EOTF to use.

- Auto - (default)
- SDR - Standard Dynamic Range
- PQ -
- HLG (Hybrid Log Gamma) - No meta-data for Digital Primaries.

### Luminance

- Auto - (default)
- YCbCr -
- ICtCp - IPT color space

## Digital Primaries

---

Selecting Custom HDR Mode allows the editing of digital primaries information that is passed as metadata accompanying the video signal. However, when HLG selected as the EOTF digital primaries information cannot be edited, because HLG does not use metadata.

### Display Mastering Luminance

---

Represents the minimum and maximum Display Mastering Luminance.

- **Minimum:** Defines the floor of the SMPTE ST 2086 color volume (in the case of HDR) and is determined by the mastering environment.
  - Range: 0.0000 cd/m<sup>2</sup> to 1.0000 cd/m<sup>2</sup>.
  - Step size: 0.0002 cd/m<sup>2</sup>.
- **Maximum:** Defines the ceiling of the SMPTE ST 2086 color volume (in the case of HDR) and is determined by the mastering environment.
  - Range: 1 cd/m<sup>2</sup> to 65535 cd/m<sup>2</sup>.
  - Step size: 1 cd/m<sup>2</sup>.

### Maximum Content Light Level (CLL)

---

Represents the highest-value pixel component in an entire scene. It is determined by analyzing each frame of video, and can be determined in the post environment.

- Range: 1 cd/m<sup>2</sup> to 65535 cd/m<sup>2</sup>.
- Step size: 1 cd/m<sup>2</sup>.

### Maximum Frame Average Light Level (FALL)

---

Represents the maximum of frame-based average light levels taken over an entire scene, and can be determined in the post environment.

- Range: 1 cd/m<sup>2</sup> to 65535 cd/m<sup>2</sup>.
- Step size: 1 cd/m<sup>2</sup>.

## HDR Playback Settings

---

The HDR Playback tab settings are identical to the HDR Capture settings, but affect the KONA IP's HDMI and SDI outputs.

# Video Setup Screen

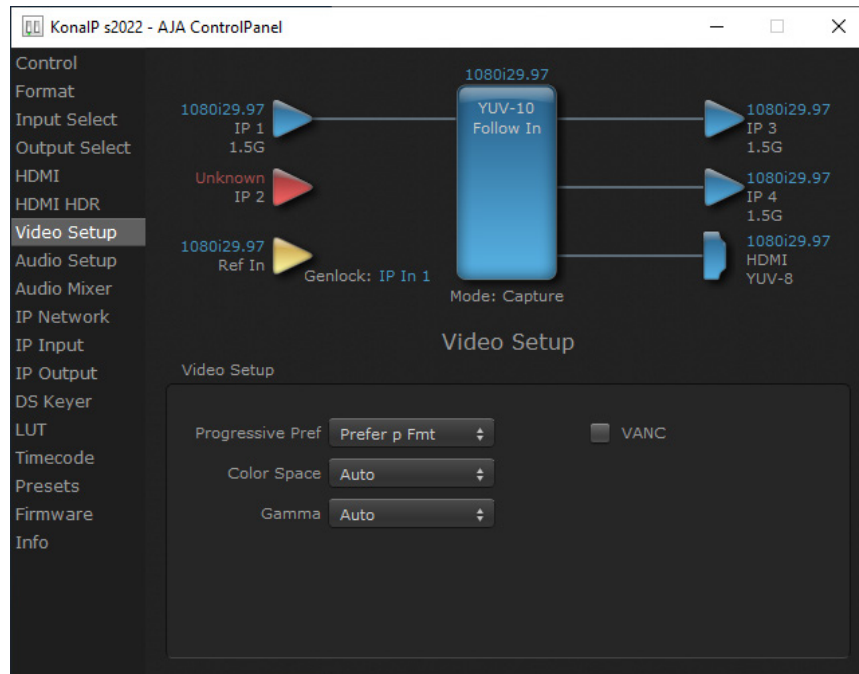

The Video Setup screen shows various other settings which will affect how video inputs and outputs behave, and how KONA IP interacts with some software applications.

## Video Setup

### Progressive Pref

This feature is used to default the hardware to use either p (progressive frames) or PsF (progressive segmented frames) output when it has not been specified by the application.

### Color Space

Sets the video color space. Select from:

- Auto
- Rec 601
- Rec 709

### Gamma

Sets the video gamma. Intended for use with legacy Apple displays. Select from:

- Auto
- Gamma 1.8

### VANC Checkbox (inactive on KONA IP)

This checkbox enables the tall frame buffers that include VANC, which is not supported by KONA IP. When using SMPTE ST 2110 the video flow is the video raster only. VANC/HANC is sent on a separate IP flow, along with audio. ST 2110 is designed to support separate essence flows for each data type.

## Audio Setup Screen

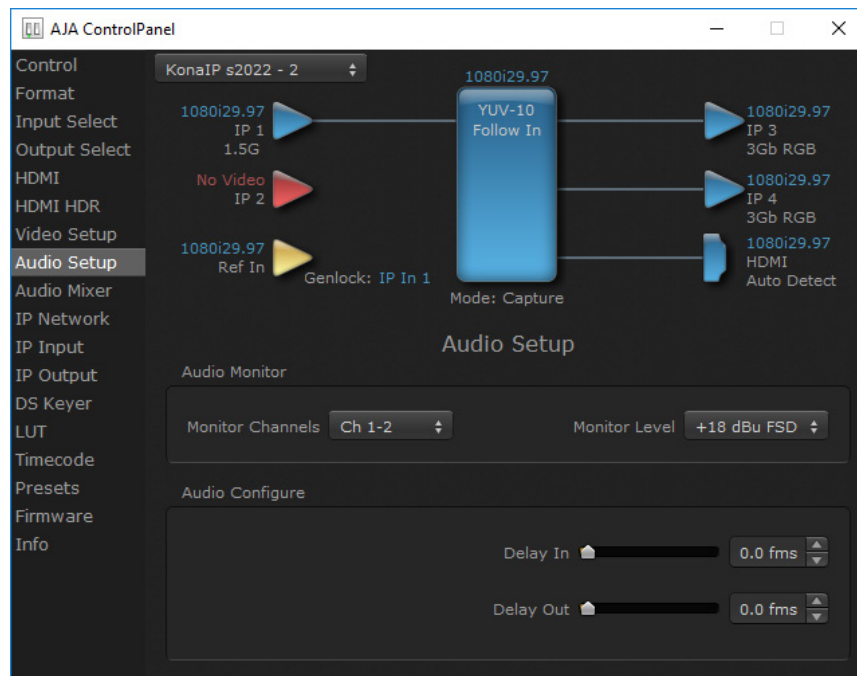

The Audio Setup Screen shows the current settings for the audio output, allowing you to re-configure it when desired.

## Audio Monitor

### Monitor Channels

Use the drop-down menu to select which two audio channels to monitor. Select from:

- Ch 1-2 through Ch 15-16.

**NOTE:** This setting only applies to dual channel monitoring environments.

### Monitor Level

Allows adjustment of the analog monitor level, to match the audio to your operating levels. Select from:

- +24 dBu FSD
- +18 dBu FSD (default)
- +15 dBu FSD
- +12 dBu FSD

## Audio Configure

Here you can set up to 6 frames (in tenths of a frame) of delay for KONA IP audio input and output. The AJA Control Panel delays all audio outputs—SDI, HDMI, and Analog.

**IMPORTANT:** If you use this Control Panel delay, do not use other delay settings in your applications. They can conflict.

## Audio Mixer Screen

---

The Audio Mixer screen has two tabs; Playback and Capture. These tabs display what sources are available for monitoring / mixing via the AJA hardware when in either of those two modes (if applicable). The controls on this screen are dedicated only to monitoring adjustments, and do not affect the level at which inbound audio signals are captured to storage.

The selection check boxes and screen slider controls affect the following KONA IP, outputs:

- IP Video Embedded Audio Out
- HDMI Embedded Audio Out

*IMPORTANT: Even though you can hear changes in the signals and levels adjusted with the Audio Mixer screen, these changes are NOT recorded to disk during NLE Capture or Audio Punch In / Voice Over to Timeline. In addition, muting or activating sources on this screen will not affect audio signals being recorded. The Audio Mixer screen is dedicated for monitoring only, not program mixing.*

The branching arrow on the lower right indicates which sources are being routed for monitoring in that operating mode, and is colored blue when active and red when disabled.

Each source has a confidence meter, which enables you to tell immediately if you have a source arriving correctly at the AJA hardware (without having to launch any other software). The level sliders allow a simple plus or minus adjustment to the Source level being monitored. This is to allow for fine-tuning of your listening environment (on occasions the host system audio can be unexpectedly loud, or an incoming feed may be very loud or very quiet).

Two different Audio Mixer screens are available, selected by clicking on the Playback Monitor or Capture Monitor tabs. During regular editing, the Playback tab is used to control your monitoring experience. During capture operations, the Capture tab is used for your monitoring experience.

Controls in each tab are only in effect when KONA IP, is in the correct operating mode, as determined by the controlling application or the Control Panel application's Default State setting. When the mode doesn't match, the mode indicator on the right goes red (see Figure 51 on page 69). However, settings can be adjusted while in that disabled mode, and will be applied when you return to that operating mode.

## Audio Mixer Playback Monitor Tab

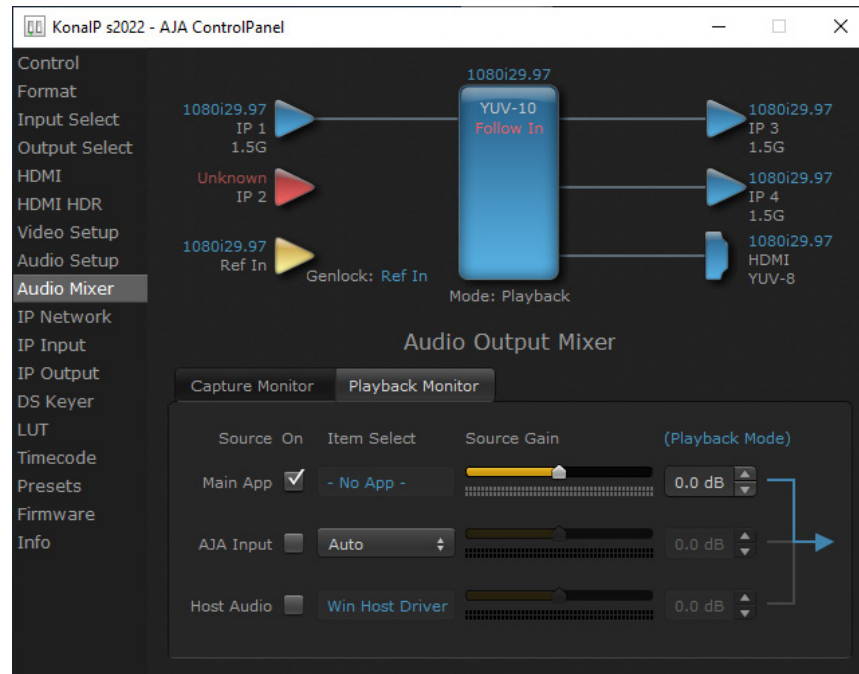

### Playback Source Selection

Clicking the On checkbox selects the audio for that item for playback to the audio monitor outputs. Multiple sources can be selected simultaneously.

#### Main App

If an external application is controlling the KONA IP, it will be displayed in the Item Select column and its audio can be selected for playback with the checkbox.

#### AJA Input

Selects the audio being input to KONA IP for monitoring

- IP Video Ch 1-16 - All 16 embedded audio channels via discrete audio essence within the ST 2110 payload are selected for input monitoring.

#### Host Audio

Selects the audio from the host computer, thus enabling the AJA hardware to monitor anything that would normally be presented via the host laptop, CPU or computer monitor. For example, an editor could sample music from an online library, while concurrently playing back their NLE timeline. Or, a producer and editor could be communicating live during an editing session, using Skype or some other video calling tool.

#### Source Gain

Meters display the input audio levels of the source, colored green when that source is On, and gray when that source is not selected. The levels shown do not change when the gain is adjusted, because the input levels are being monitored, not the output levels.

When activated, the source gain controls can be used to adjust the monitoring output gain of that source, from +6dB to - infinity (mute). Adjustment methods include:

- Sliders - The sliders on the right can be used to change the values for each color.
- Numeric Entry - You can enter a numeric value by clicking on the displayed number, and can then increase or decrease the values by clicking on the up/down arrow boxes.
- Cut and Paste - Right clicking on a displayed number opens a Cut, Copy, Paste dropdown menu for convenient numeric entry.

As mentioned before, these controls are for monitoring only, and do not change the audio recorded to a NLE file. Any actual recording level adjustments to Capture or Audio Punch In / Voice Over to Timeline operations will either need to be made upstream of the AJA input, or else via adjustments within the main NLE application (e.g. via a pass through mix tool).

## Audio Mixer Capture Monitor Tab

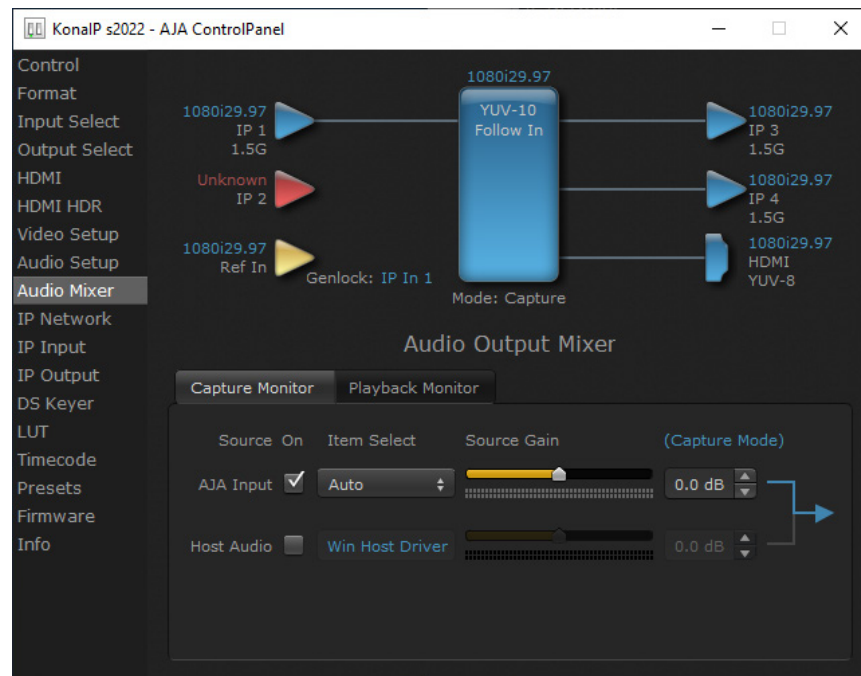

The Capture Monitor Mode screen is used to select and mix audio to be monitored during capture operations.

**IMPORTANT:** Even though you can hear changes in the signals and levels adjusted with the Audio Mixer screen, these changes are NOT recorded to disk during NLE Capture or Audio Punch In / Voice Over to Timeline. In addition, muting or activating sources on this screen will not affect audio signals being recorded. The Audio Mixer screen is dedicated for monitoring only, not program mixing.

The controls on this screen are similar to those on the Playback Monitor Mode screen, except the Main App is not available for selection (you cannot capture from the application that is capturing). See ["Audio Mixer Playback Monitor Tab" on page 38](#) for more information.

**NOTE:** If you want different behavior when the Capture tab is triggered; i.e. for host system audio to be muted, then simply check the host system audio in the Capture tab only. This way when you exit NLE Capture and return to regular editing, the Playback tab settings will be applied and your host system audio monitoring will resume.

# IP Network Screen

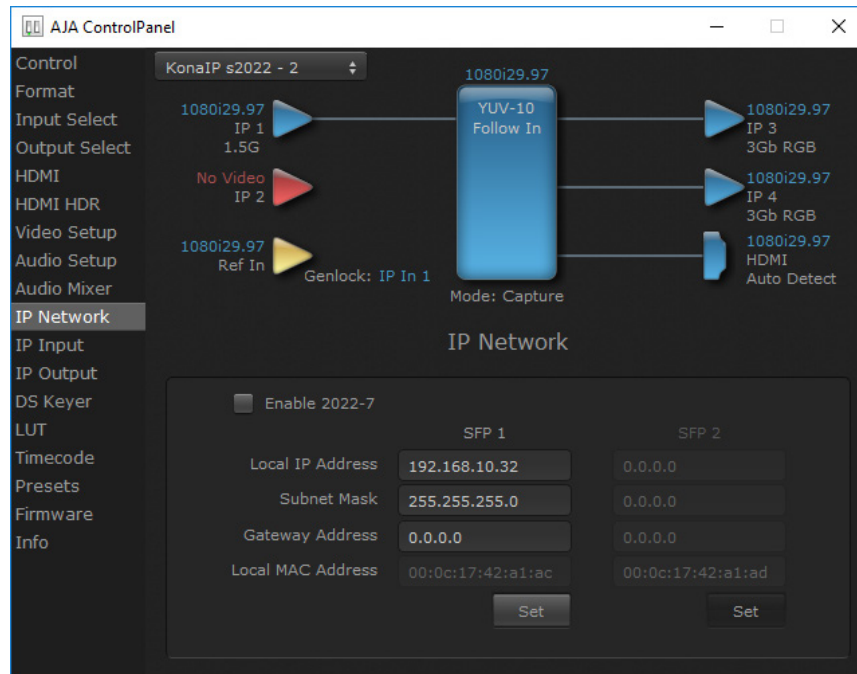

The IP Network Screen lets you input the network parameters that define the location of each physical SFP+ cage of the KONA IP hardware.

## Enable 2022-7

Enables ST 2022-7 redundant network operation. See ["IP Network Screen, ST 2022-7 Operation" on page 41](#) for more information.

## Local IP Address

This is the IP address that identifies each physical KONA IP SFP+ link on the network. This field must be filled in for at least one of the KONA IP SFPs for KONA IP to work properly.

## Subnet Mask

This is the subnet mask defined by the system administrator. Generally speaking, this value must be defined in the AJA Control Panel for KONA IP to work correctly on the network.

## Gateway Address

This is the IP address of a network gateway to a remote network. This value must be defined if/when the KONA IP needs to send signals to, or receive signals from a remote network.

## Local MAC Address

This is an information display field that cannot be changed. It is the MAC address that is assigned to the specific SFP cage on the KONA IP.

## Set Button

Click the 'Set' button to apply the changes.

## IP Network Screen, ST 2022-7 Operation

Enabling 2022-7 makes it possible to configure redundant networking capabilities using both SFP modules. In ST 2022-7 operation each SFP transmits and receives the same information. This allows the use of two separate network paths, making recovery possible if one path fails.

Figure 12. AJA Control Panel, IP Network Screen with ST 2022-7 Enabled

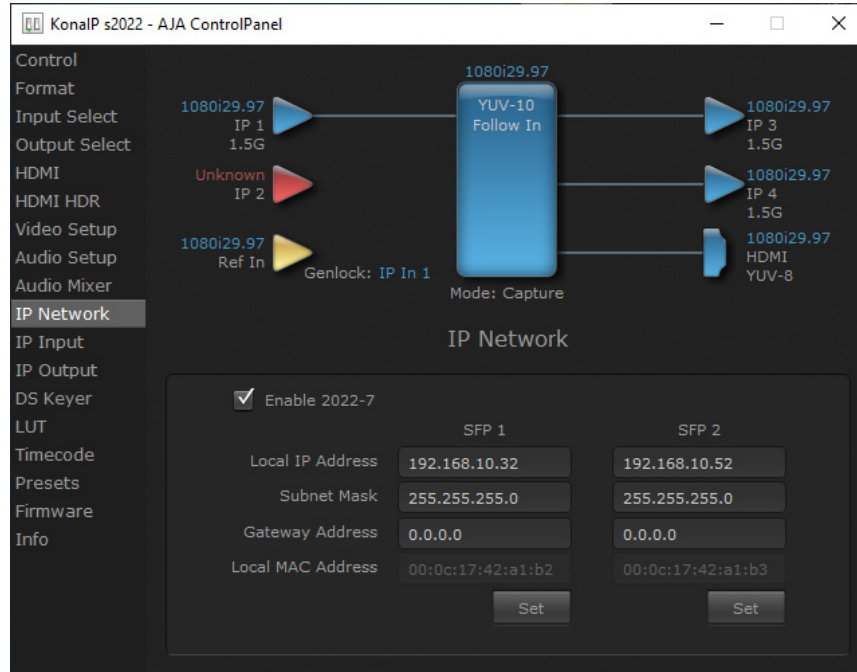

When ST 2022-7 is enabled, additional settings are available for configuring your network settings.

- SFP 1 - Indicates the top physical SFP cage on the KONA IP board, farthest from the copper contacts where the KONA IP connects to its PCIe slot.
- SFP 2 - Indicates the bottom physical SFP cage on the KONA IP board closest to the copper contacts where the KONA IP connects to its PCIe slot.

# IP Input Screen

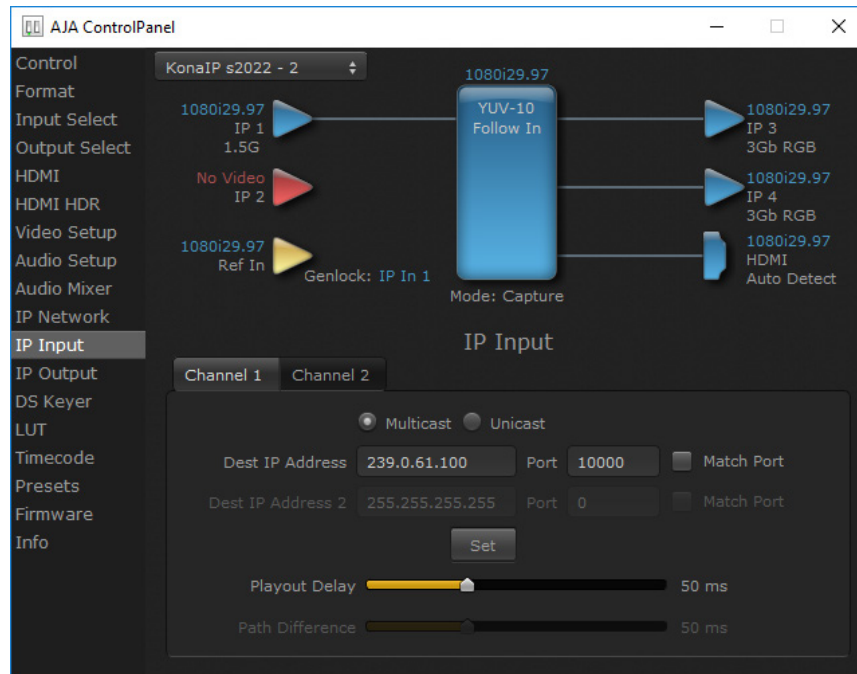

The IP Input Screen on KONA IP lets you define parameters for receiving inputs to the KONA IP from another device on the network.

*NOTE: The IP 1 Input and IP 2 Input labels do not represent the physical SFP cages on the KONA IP. They represent different transmissions being received by the KONA IP card, possibly over the same 10 GigE link.*

## Channel 1, Channel 2 Tabs

Select the input channel to be configured.

## Multicast

When selected, Multicast operation is used. Enter a valid multicast IP address into the Dest IP Address field.

## Unicast

When selected, Unicast operation is used. The Dest IP Address field is automatically filled with that card's Local IP Address (from the IP Network screen) and the field will be grayed out (not editable).

*NOTE: Turning off Unicast operation makes the Dest IP Address editable, but it retains the previously applied Unicast IP address. You must edit the Dest IP Address field on this screen to resume Multicast operation.*

## Destination IP Addr

This filter lets you specify the network address where a multicast from another device on the network can be found.

## Destination Port

This filter lets you specify the port number being used to send a multicast to the 'Destination IP' address specified above.

## Destination IP Addr 2

This field will only be available when ST 2022-7 is Enabled in the IP Network section. This filter lets you specify the network address where a duplicate multicast from another ST 2022-7 device on the network can be found. That device should be sending two duplicate IP video multicasts and the IP addresses of those streams will be specified in 'Destination IP Addr' and 'Destination IP Addr 2'.

## Destination Port 2

This filter lets you specify the port number being used to send a multicast to the 'Destination IP Addr 2' address specified above.

## Match Checkboxes

The 'Match' checkbox can be used to match the Destination Port to the Destination IP Address.

## Playout Delay

The Playout Delay slider can be used to adjust the amount of buffering before packets are sent to the network, in a range of 0 to 150 milliseconds. Network traffic conditions may require setting a larger buffer. Default is 50 milliseconds.

## Path Difference (ST 2022-7 only)

The Path Difference slider can be used to adjust the buffering used for redundant operation, where the paths through the network of the two streams may have different delays. Adjustable in a range of 0 to 150 milliseconds, with 50 milliseconds the default. See ["IP Network Screen, ST 2022-7 Operation" on page 41](#).

## IP Output Screen

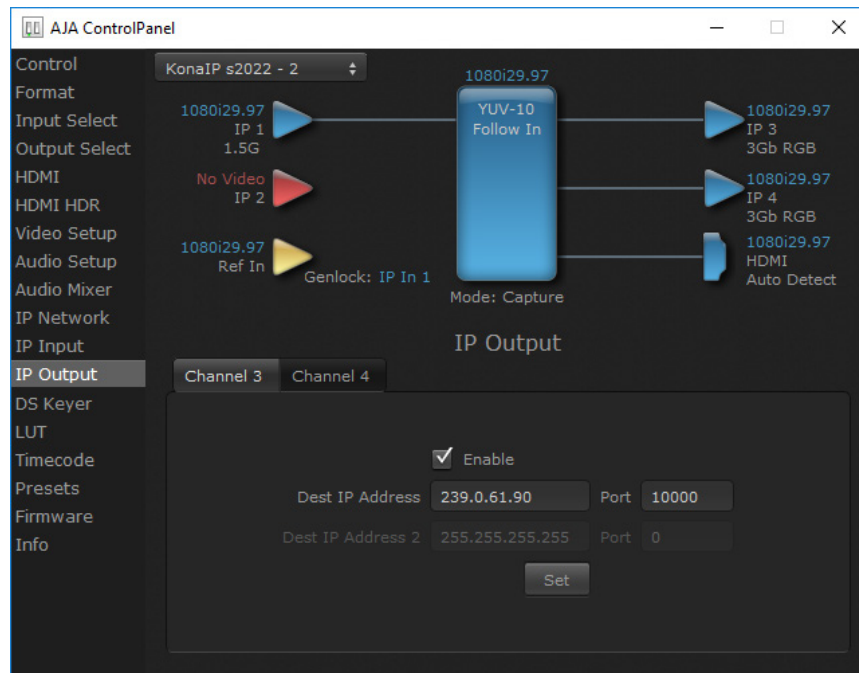

The IP Output Screen on KONA IP lets you define parameters for sending outputs from the KONA IP card onto the network.

## Destination IP Addr

This parameter lets you specify the network address where a multicast from this KONA IP can be sent for use by other devices on the network.

## Destination Port

This lets you specify the port number being used to send a multicast to the Destination IP address specified above.

## Destination IP Addr 2

This field will only be available when ST 2022-7 is Enabled in the IP Network section. This filter lets you specify the network address where a duplicate multicast from this KONA IP output can be sent. This IP output will then be sent to both the address specified in 'Remote IP Addr', and also to the address specified in 'Remote IP Addr 2'.

## Destination Port 2

This field will only be available when ST 2022-7. It lets you specify the port number being used to send a multicast to the 'Remote IP Addr 2' address specified above.

## Enable Checkbox

The 'Enable' checkbox connects the KONA IP to the network address specified by all the matched output parameters. Any time a parameter is changed, the output should be re-enabled.

## Downstream Keyer Screen

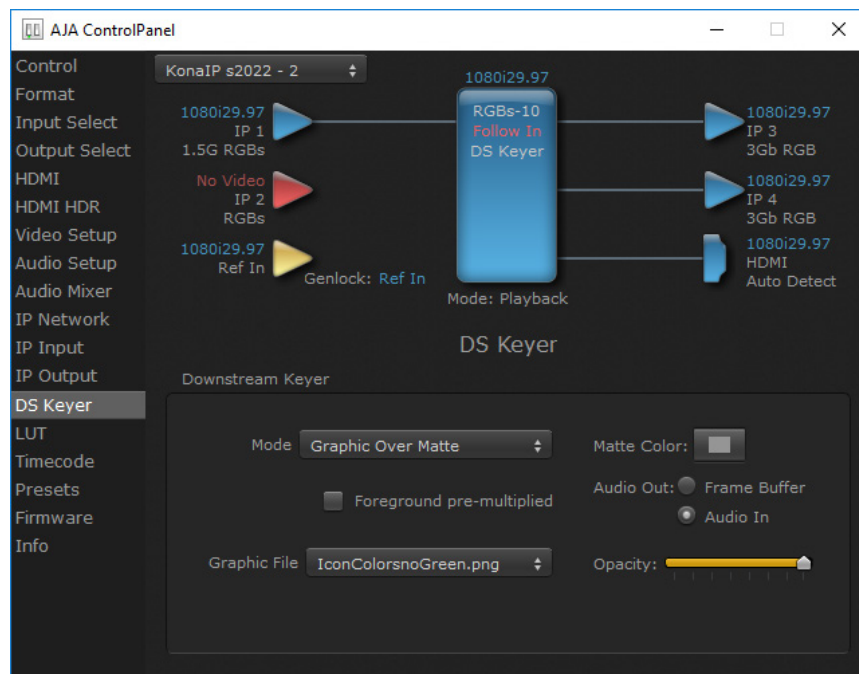

KONA IP has a hardware-based downstream keyer that is ideal for putting logos, "bugs" or other video material with an alpha channel on top of video being played out or printed to tape. A typical application would be putting a television station's call letters or channel over program video content. Keyed video can be from the KONA IP's internal Frame Buffer (from storage, video In, KONA TV, etc.) or from a graphics file that has an alpha channel (PhotoShop etc.).

Settings in the DS Keyer Screen provide control over how the keyer operates and whether it's turned on or off. Controls and their meanings in the screen are as follows:

## Downstream Keyer Mode

---

### Downstream Keyer Off

---

When this pulldown menu item is selected the downstream keyer will be turned off.

### Frame Buffer over Matte

---

Places the keyed video with alpha channel currently in the Frame Buffer over a fixed color matte determined by the "Matte Color" setting set separately.

### Frame Buffer over Video In

---

Places the keyed video currently in the Frame Buffer over the video input for playout or print-to-tape.

### Graphic over Matte

---

Places a graphics file having an alpha channel (chosen in "Graphic File" pulldown) over a fixed color matte determined by the "Matte Color" setting set separately.

### Graphic over Video In

---

Places a graphics file having an alpha channel (chosen in "Graphic File" pulldown) over the video input for playout or print-to-tape.

### Graphic over Frame Buffer

---

Places a graphics file having an alpha channel (chosen in "Graphic File" pulldown) over the current contents of the KONA IP's Frame Buffer (which might be from storage, video In, KONA TV, etc.).

## Matte Color

---

Only available when the pulldown "Frame Buffer over Matte" or "Graphic over Matte" are selected-pressing this button brings up a color selection dialog. The dialog provides a variety of ways to select a matte color including a color wheel, color picker (choose from a location anywhere on the computer screen), numeric sliders, swatches, "crayons", and spectrums. The matte chosen will be used as a video background under the keyed video.

## Foreground pre-multiplied (checkbox)

---

Use to avoid "matte lines" and improve the appearance of the foreground (key) being composited over the background.

## Audio Out

---

### Frame Buffer

---

Select audio out to be routed from the contents of the Frame Buffer.

## Audio In

Select audio out to be routed from KONA IP's currently selected input(s).

## Opacity

This slider controls the transparency of the keyed video (over the background) from translucent to completely opaque.

## Graphic File Load

This pulldown allows you to choose from any recently accessed file or select a new file ("Load File..."), which then brings up a file dialogue. Remember that the file raster (pixel x pixel count) should match the primary format in the frame buffer. Example: you wish to key a logo on top of your 1920x1080 footage, the still image with alpha channel that you load should be 1920x1080.

## LUT Screen

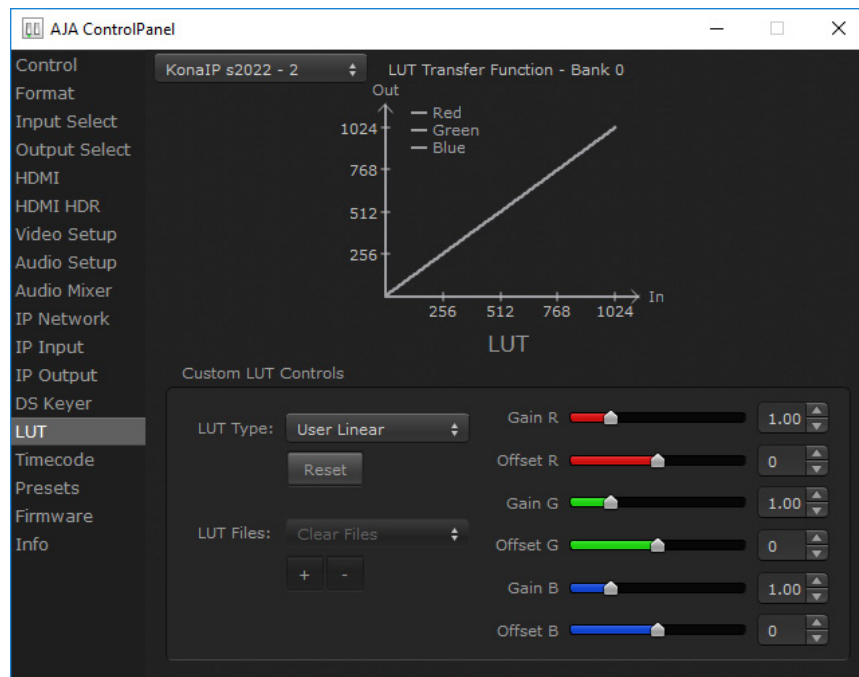

This screen lets you control RGB look up table (LUT) color conversion. You can let KONA IP automatically apply LUT conversion as appropriate, or you can load and adjust LUT data to meet your requirements. The frame buffer must be set to RGB (Format screen, Pixel Format) to enable, apply, and adjust LUT conversions.

*NOTE: KONA IP also uses a hardware based color-space converter in conjunction with the LUT. For example,*

## LUT Transfer Function

The upper right side of the LUT screen displays an approximate representation of the Red, Green, and Blue curves of the current transfer function.

*NOTE: The LUT Transfer Function display may not always be an accurate representation of the color conversion being applied. For example, if other parameters are not set correctly, you may be able to change the curves on the screen but that conversion is not applied to the output until the parameters are adjusted correctly.*

## LUT Type

---

Select the type of LUT. Choose from

### Auto (default)

---

When the Frame Buffer is set to **RGB** and LUT Type is set to **Auto** the type of LUT automatically loaded is determined by the video format and how the video output(s) are configured.

- For SD format and YUV output, the LUT is automatically loaded with a REC601 gamma.
- For HD format and YUV output, the LUT is automatically loaded with a REC709 Gamma.
- For HD format and RGB output (e.g. dual link RGB), the LUT is automatically loaded with linear since both the buffer and output are both RGB (1:1).
- For an RGB source and RGB output, and for a YUV source and YUV output, the LUT will be linear because no conversion is taking place.
- For an RGB source and a YUV output (common if receiving files from an animator or motion graphics artist), and vice versa, then Auto will apply the proper curve to enable this (along with a color space conversion).

### Linear

---

Forces a straight linear transfer function.

### SMPTE->FullRange

---

Forces a SMPTE to Full Range transfer function.

### FullRange->SMPTE

---

Forces a Full Range to SMPTE transfer function.

### User Linear

---

On first use, sets a linear transfer function and activates the Gain and Offset sliders on the right, permitting individual Red, Green, and Blue color adjustments. These settings are retained if you select another LUT type and then return to this setting.

### User Film Stream

---

Similar to User Linear, above but sets a film style transfer function that can be adjusted with the Gain and Offset sliders.

### User LUT File

---

Activates the LUT Files controls, allowing the loading of a custom LUT .txt file. See ["User Defined LUTs" on page 48](#).

## Reset Button

---

Returns the settings of the currently selected LUT type to their default values.

## Gain and Offset Sliders

---

When a User setting is selected, individual sliders for Gain and Offset for Red, Green, and Blue are activated.

## User Defined LUTs

---

Users can specify their own custom LUTs by creating a LUT file and uploading it to an AJA Video Device using the LUT (lookup table) screen in the Control Panel. You can create a custom LUT file using most text editors or spread sheets, provided the data is arranged according to the LUT File Format Specification (see "[LUT File Format Specification](#)" on page 48).

### Uploading A Custom User LUT File

---

Once the LUT file is created, you can upload it with the following steps:

1. Before loading a LUT, make sure you are using an RGB frame buffer format. Go to the Format screen and adjust the Pixel Format.
2. Open AJA Control Panel and select the "LUT" screen.
3. Click the "LUT Type" popup and choose "User LUT File". LUT Files options become enabled.
4. Click the "+" button and use the navigation dialog to choose a custom LUT file. The file is loaded and the LUT will be applied, if it is properly formatted.

### LUT File Format Specification

---

LUT files are normal text files that contain 1025 lines (numbered 0 - 1024).

Each line contains 3 integer values in the range 0 - 1023, representing 10 bit R, G, B component output values. Component values may be separated by one or more commas, spaces, or tabs. The example below show LUT File contents for Line 0, Line 1, Line 2, and Line 1024, with different valid ways to separate the numbers in a line.

- 16, 17, 17
- 17 18 18
- 19 19 21
- ...
- 1000, 1022, 1023

In the example above, the first line (Line 0) represents the output values for the case where R=0, G=0, or B=0. In other words, if the R component of a pixel is set to 0, then set R component value to 16. Likewise, if G is set to 0, then set G to 17. The second line (Line 1) does a similar thing for input component values equal to 1.

A simple way to construct a LUT file is to use a Spreadsheet like Excel. Simply fill 3 columns and 1025 rows with LUT data, and save the result as a "CSV" file.

# Timecode Screen

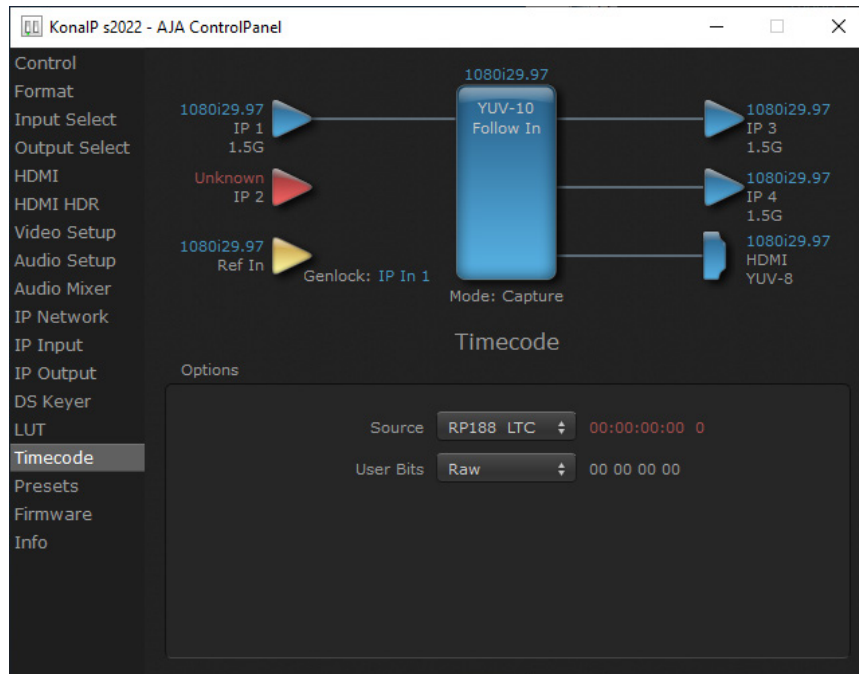

The Timecode Screen selects the timecode stream read for applications that use it (for example, when the timecode source is set to “Use control panel setting,” AJA Control Room will read the selected stream). It is also used for monitoring the RP-188 timecode embedded in the digital data stream, and can be used for selecting a timecode offset (if required).

## Options

### Source

In RP-188 timecode (SMPTE 12M-2) there can be multiple timecode types in the data stream. Use this pull-down to select the one you wish to monitor:

- RP188 LTC (Linear timecode)
- RP188 VITC (Vertical Interval timecode)

The selection will be displayed in the timecode value to the right of the pull-down.

### User Bits

Select from Raw or VFR. For monitoring a variable framerate (VFR) timecode (such as Varicam), you may wish to select VFR for User-bits. KONA will detect and interpret the user-bits and display them next to the checkbox. You will see the original framerate (30 fps in the figure below) followed by the adjusted frame padding (two digits reporting discarded and retained frame padding).

**NOTE:** SMPTE 12M-2 is the updated name and specification for what was RP-188. SMPTE RP 188 defines a standard for the transmission of time code and control code in the ancillary data space of a digital television data stream. Time code information is transmitted in the ancillary data space as defined in ANSI/SMPTE 291M. Multiple codes can be transmitted within a single digital video data stream. Other time information, such as real time clock, DTTR tape timer information, and other user-defined information, may also be carried in the ancillary time code packet instead of time code. The actual information transmitted through the interface is identified by the coding of a distributed binary bit. Equipment manufacturers can use the meta data for different purposes.

## Presets Screen

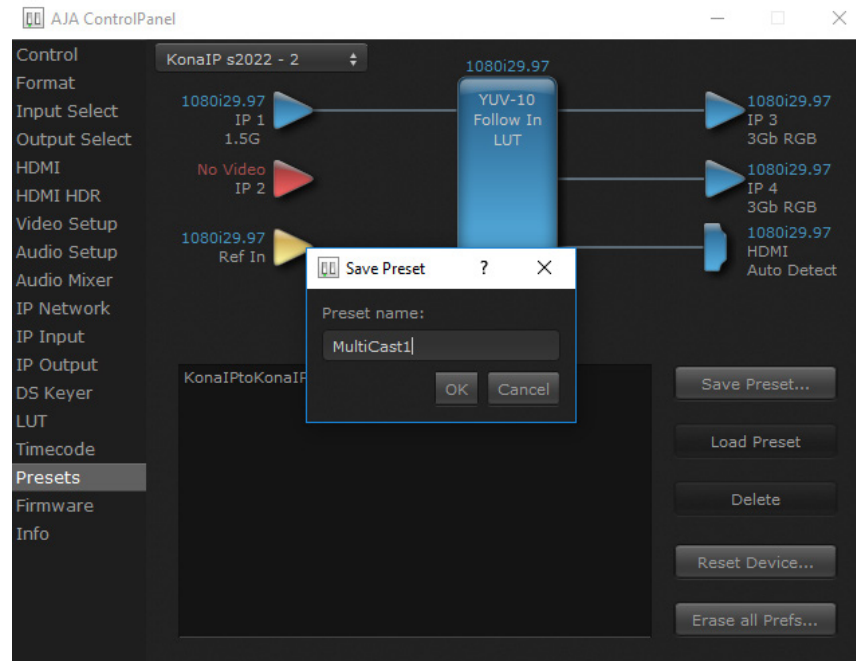

After configuring the AJA Control Panel screens, you can then save all your settings as a snapshot for later recall, called a preset. In this way, you can organize presets for all your typical tasks, eliminating manual reconfiguration.

## Saving, Loading and Deleting Presets

To save a preset, simply go to the Presets screen and click “Save Preset”. A dialog will be presented asking you for a file name. Enter a meaningful name and click “OK”. Thereafter the preset will be available under the Control Panel “Presets” list.

From the Presets screen you can manage your collection of presets easily. To Load or Delete a stored preset, just select it with your mouse and then click the “Load Preset” or “Delete” button respectively .

## Transferring Saved Presets

If you want to use a saved Preset on another workstation, you can simply copy the file on removable storage and install it at the new location. The Preset files are stored at:

### Mac OS Preset Files Storage Location

- From the Finder, hold down the Option key (to display the Library directory) and click on Go/Library/Application Support/AJA/<device name>/Presets/

## Windows Preset Files Storage Location

- c:\Users\

## Reset to Default

When you click the "Reset Device" button the Default User Preference file will be deleted and AJA Control Panel will do one of the following:

- If a Default Global Preference is found, it is loaded and the device is set to this state.
- If a Default Global Preference file is not found, "factory defaults" are loaded and the device is set to this state.

*NOTE: See "Default Preferences" on page 22 for more information.*

## Erase all Prefs

For technical support purposes you may be required to remove the current Preference settings. Clicking on the "Erase all Prefs" button deletes the current Default User Preference file without accessing a Default Global Preference file, if one exists. Current AJA device settings are not altered, but changing any setting will immediately regenerate a Default User Preference file with the changed settings.

*NOTE: Clicking on the AJA Control Panel Erase All Prefs button does NOT delete an existing Global Preference file from that shared location.*

## Firmware Screen

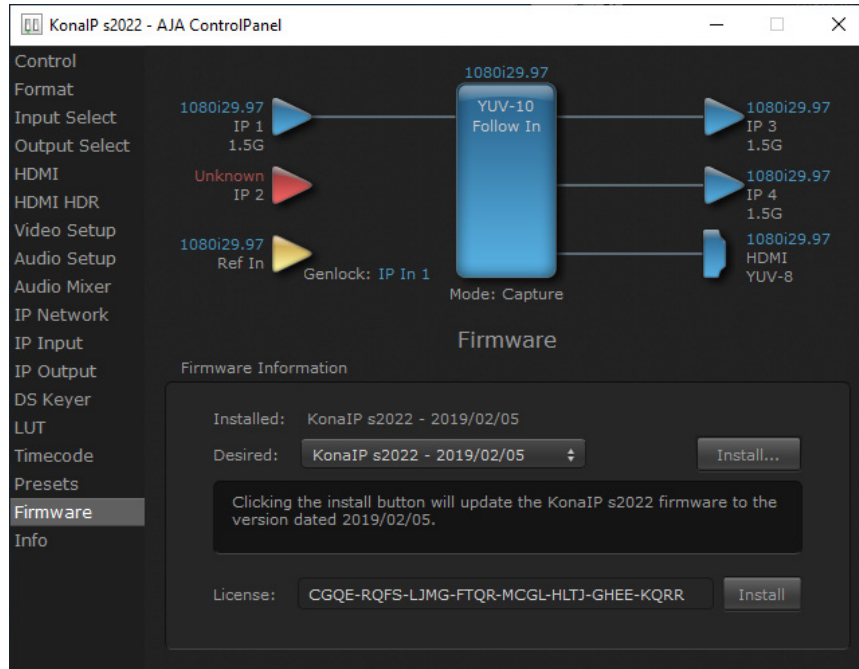

Three versions of firmware are available for KONA IP. You can select from:

- KonaIP s2022 - For use only with 2022-6 full bandwidth video.
- KonaIP J2K - With purchase and installation of an optional license, adds JPEG 2000 compressed video capabilities.
- KonaIP s2110 - Permits granular transport of individual or groups of video and audio streams.

**NOTE:** When you change between operating modes, you may need to connect to a different physical media network, or reconfigure that media network for compatible operation.

Click **Install** to erase the current firmware and load the desired firmware.

You will be required to power-cycle your computer to finish the changeover.

## Info Screen

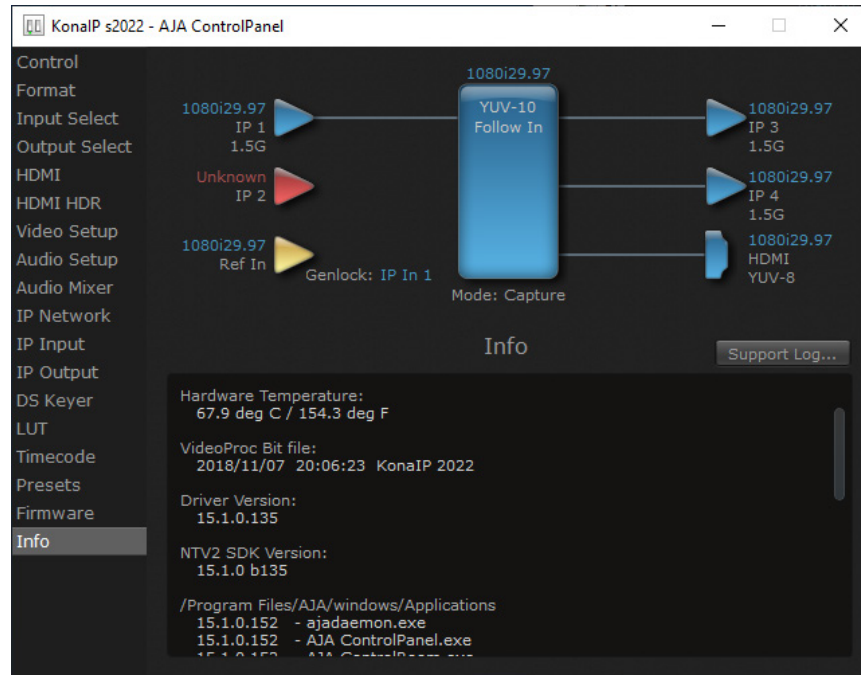

This screen shows the KONA IP software files that have been installed on your system. This information may be needed if you talk to an AJA Customer Service representative to determine if files are missing or need updating.

## Control Panel Operation in ST 2110 Mode

### Overview

KONA IP's ST 2110 mode supports the transport of uncompressed SDI video (up to 4Kp60) and embedded digital audio streams over a network. These audio and video streams can be sent and received independently.

### Requirements

- 10G network
- PTP network timing system

### General Operation

In ST 2110 mode, a new KONA IP must be configured before operation. Once initially configured, that KONA IP can be set to receive JSON or SDP information, which completes that device's configuration for a specific workflow task (playing back and/or capturing SDI video and audio over the network).

Because of the complexity of setting up IP configurations for ST 2110 operation, IT experts at your facility may have created a set of files you can use for quick and easy KONA IP re-configuration. A shared network location or other method may also be established to hold these files, to ensure easy access to the correct configuration files for various workflows.

### AJA Control Panel ST 2110 Mode Follow Input Settings

The correct setting of AJA's Control Panel application's "Follow Input" parameter is required, depending on the type of transport:

- **Follow Input** should be **On** for HD/SD SDPs.
- **Follow Input** should be **Off** for script to script configurations. The frame rate will need to be manually set.
- **Follow Input** should be **Off** for UltraHD/4K SDP's, which will maintain the board in UltraHD/4K operation.

### AJA Device ST 2110 Mode Presets and Resets

Control Panel user defined Presets save and restore the video state and video options currently set in Control Panel. IP parameters are not included. Use exported scripts to save IP parameters.

The Control Panel "Reset Device" button reset clears all IP settings and puts the card back to fresh state. This is recommended when setting up a new script or generating a new set of parameters, but is not required.

## IP Config Status Tab

The Control Panel screens available in ST 2110 mode are similar to those in ST 2022-6 mode. The IP Config screen parameters are arranged differently, however, with three tabs.

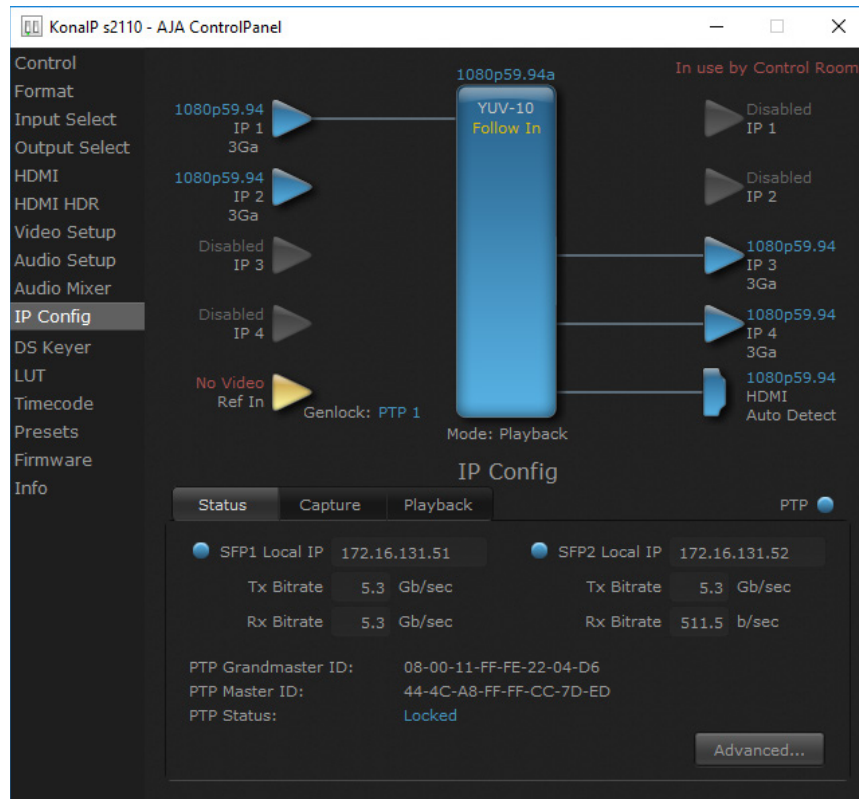

The ST 2110 Status screen reports various network statuses, including IP addresses and PTP operation. It also permits access to IP configuration options.

## SFP1 Local IP

The Local IP address of the top SFP is displayed. The current transmit and receive bitrates are also reported, in Gb/sec.

## SFP2 Local IP

Same as above, but for the lower SFP module, if installed.

## PTP Information

The PTP Grandmaster and Master IDs are displayed, as well as the current PTP Status.

## Advanced Button

Clicking on the Advanced button takes you to the 2110 IP configuration windows. See ["IP Config Editor Window" on page 57](#) for more information.

## IP Config Capture Tab

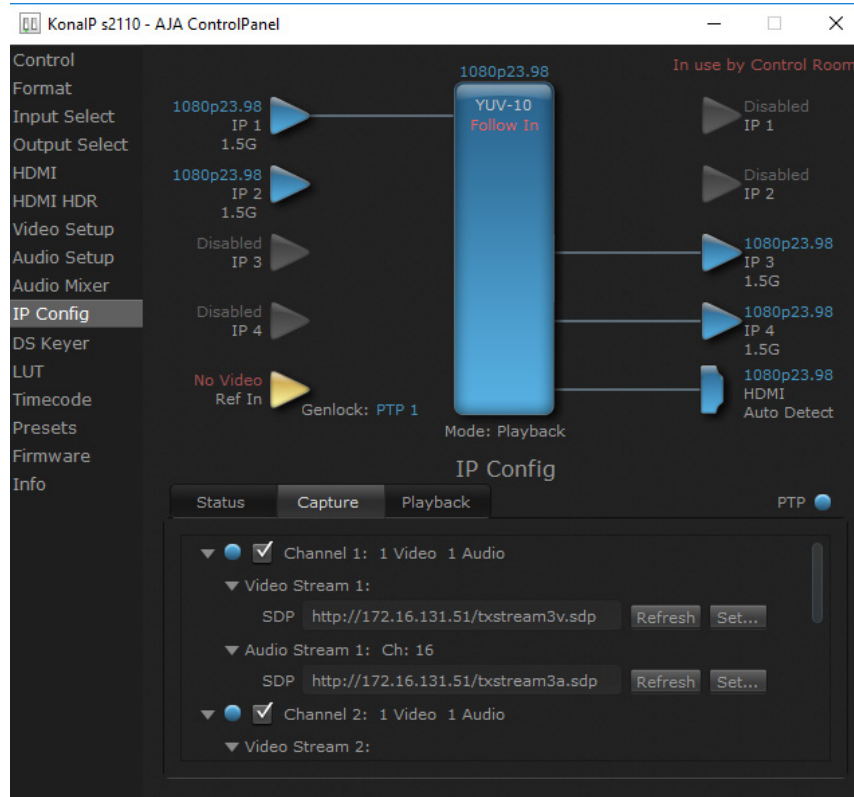

The Capture Tab screen shows the current settings for receiving IP streams, the status of that stream, and allows activating and deactivating each stream.

Session Description Protocol (SDP) information, used for easy configuration, can also be loaded and refreshed from this screen.

## Channel 1-4

Click on the box to enable the configured stream (check mark). Activity of that stream is indicated by the color of the dot: blue = active, red = inactive.

Clicking on the triangles display information for that video or audio playback stream.

## SDP

---

The current SDP information is displayed for that stream.

## Refresh

---

Click **Refresh** to update the configuration information. Use when the source frame rate has changed.

## Set

---

Click **Set** to open a dialog box allowing you to enter SDP configuration information for the source of the desired stream.

- Select **URL** to enter the text of a network location where the desired SDP information resides. This can be a URL of a KONA IP transmit device.

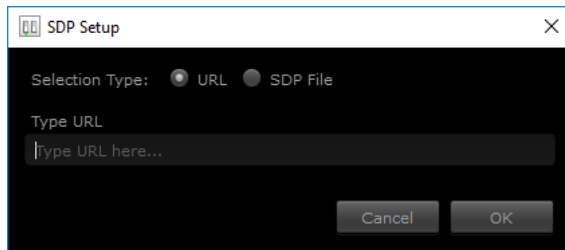

*NOTE: When using a URL for configuration, you need to turn Control Panel's "Follow Input" setting On and use Refresh if the incoming signal format changes.*

- Select **SDP File** to browse to a location with the desired SDP source stream information. The location selected must point to an SDP file that was created by the source that is transmitting the signal.

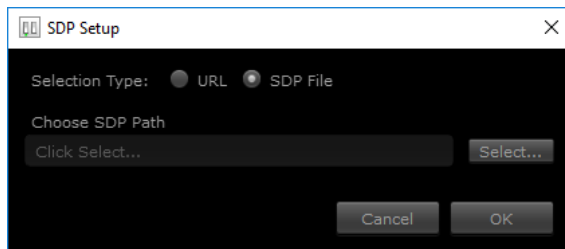

*NOTE: When using an SDP for configuration, you need to turn Control Panel's "Follow Input" setting On and if the incoming signal format changes you will need to generate and import a new SDP file to accommodate the format change.*

## IP Config Playback Tab

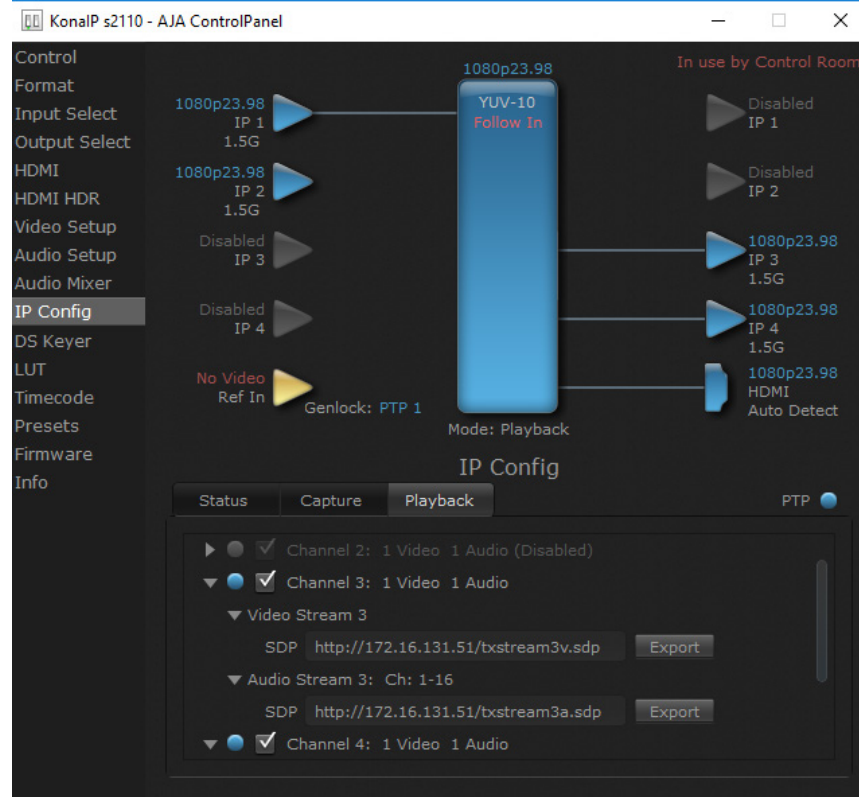

### Channel 1-4

Click on the box to enable the configured stream (check mark) Activity of that stream is indicated by the color of the dot: blue = active, red = inactive.

Clicking on the triangles display information for that video or audio playback stream.

#### SDP

The current SDP information is displayed for that stream. This text can be copied and pasted to configure another KONA IP's capture stream.

#### Export

Click **Export** to name and save an SDP configuration file for that transmit stream, which can be used to configure another KONA IP's capture stream.

## IP Config Editor Window

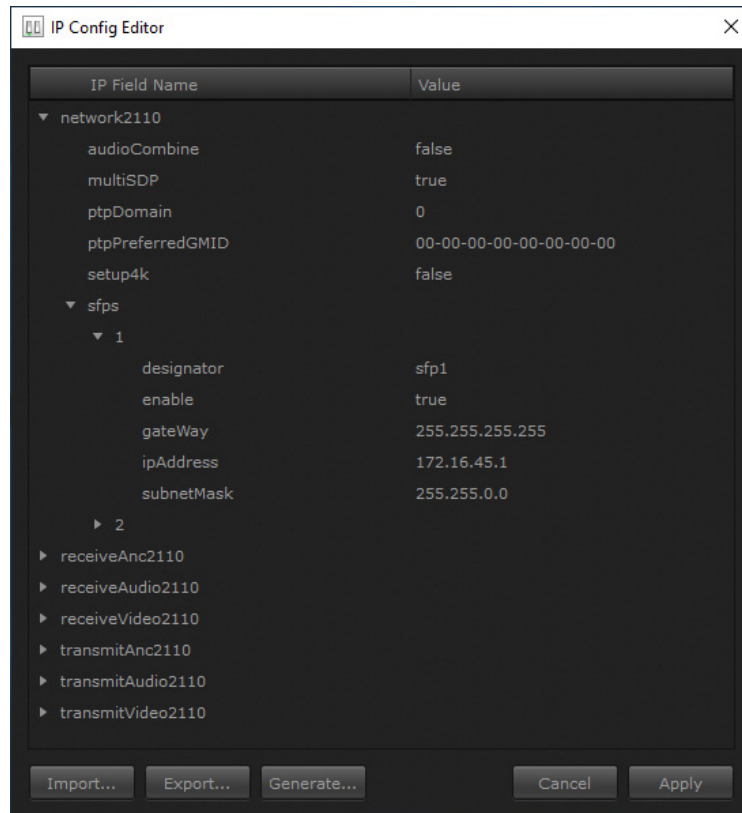

In the Status tab screen, clicking on **Advanced** opens an IP Config Editor window, used for advanced configuration. Click on the triangles to reveal editable configuration information, listed by IP Field Name and Value.

### Import

Click **Import** to open a navigation window allowing you to import a JSON file into the editor. Imported values are not activated on the KONA IP until applied.

### Export

Click **Export** to open a navigation window allowing you to name and export the current configuration as JSON file.

### Generate

Click **Generate** to open an initial IP Configuration window allowing you to create the current configuration as JSON file (see "[Generate Window](#)" on page 58).

### Cancel

Cancels any currently changed settings and closes the window.

### Apply

Click **Apply** to apply the current settings to the KONA IP's basic IP settings.

**NOTE:** Applying a basic configuration affects the KONA IP's currently configured network playback stream information, but does not affect the currently loaded capture stream information.

## Generate Window

AJA Control Panel™ Startup Options

### Generate Initial IP Configuration

This generates an IP configuration that will be a starting point for further customization.

Base IP Addresses:

SFP 172.16.131.51

Rx Destination 239.0.131.0 Port 1000

Tx Remote 239.20.131.0 Port 1000

Defaults Cancel Generate

The Generate window lets you edit and create the base IP addresses to be used by that KONA IP.

*IMPORTANT: Each KONA IP ships by default with the same SFP base IP address. This must be changed to ensure each device on the network has a unique IP address.*

### Defaults

---

Resets the IP values to factory defaults. These values are not activated on the KONA IP until applied.

### Cancel

---

Cancels any currently changed settings and closes the window.

### Generate

---

Generates a set of basic IP addresses based on the values entered above. Generated values are not activated on the KONA IP until applied.

# Chapter 4 – Advanced ST 2110 Configuration

---

This Chapter offers technical information regarding IT configuration for ST 2110 workflows, useful to IT professionals responsible for network system administration.

## Configuration Summary

---

In ST 2110 Mode, each KONA IP must be configured before operation. This configuration process can be accomplished using AJA's Control Panel software, and includes the following steps:

- Create a unique base IP address for each SFP module.
- Create JSON or SDP configuration files that determine the IP attributes of each transmit and receive stream.
- Apply the correct configuration file for each stream to the each KONA IP.

In ST 2110 Mode, KONA IP supports three configuration methods to specify the required transmit and receive stream IP information:

- **JSON Script** - Generate and apply a JavaScript Object Notation (JSON) file containing all the required information for each KONA IP. The Control Panel **Follow Input** parameter of the capture KONA IP must be turned Off, and the user manually sets the Control Panel frame buffer format to match the input. For advanced users only after initial setup.
- **SDP URL** - Enter the URL of a network location that has a desired Session Description Protocol (SDP) file for a stream to be received. This may be the URL of the transmitting KONA IP device itself. The Control Panel **Follow Input** parameter must be turned On before applying the configuration, and the operator uses **Refresh** to update the KONA IP's frame buffer format if the incoming signal format changes.
- **SDP File** - Export an SDP file from a transmit KONA IP and then import it into a receive KONA IP. This file reflects the transmit device's output configuration at the time of creation, and a new SDP file must be generated and imported if the incoming signal format changes. The Control Panel **Follow Input** parameter must be turned On before applying each configuration.

## Initial KONA IP ST 2110 Installation and Network Configuration

---

1. Install the KONA IP card with SFP module(s) into your computer.
2. Install AJA's Desktop Software package on the same computer.
3. Connect the KONA IP card's SFP module(s) to your 10 GigE media network.
4. Connect the KONA IP's HDMI output to a compatible HDMI monitor.
5. Launch AJA's Control Panel application and select **IP Config**.
6. In the Status tab, click on **Advanced**, and then click on **Generate**.

Figure 13. Generating an Initial ST 2110 Configuration

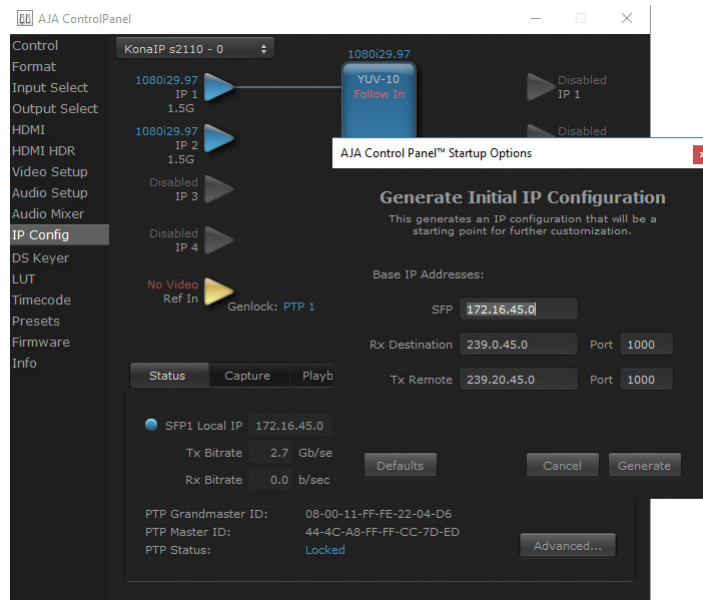

7. In the SFP field, enter a unique IP address for the KONA IP card's top SFP.

*IMPORTANT: Each KONA IP ships by default to generate the same IP address. This default address must be changed so each device on the network has a unique IP address.*

*IMPORTANT: KONA IP's automatic configuration file creation process generates a compatible set of IP addresses by incrementing the basic IP address. AJA recommends separating adjacent IP addresses for different KONA IP devices by at least two in the third octet, to keep each SFP (up to two per card) unique.*

*IMPORTANT: Keep careful records of what IP addresses have been assigned on the network to avoid accidental duplication.*

8. Click on the second window's **Generate** button, then click **Apply**. This creates a generic configuration defined with four transmit video streams, four receive video streams, four audio transmit streams, and four receive transmit streams. The various IP addresses generated are derived from the base IP value you entered.

*NOTE: Default IP addresses can be used for testing, but for actual deployment AJA recommends having a facility administrator manage IP configuration.*

9. Click on the Network triangle and enter a valid IP address for your facility's PTP master clock, which is required for ST 2110 operation.

Figure 14. PTP Configuration

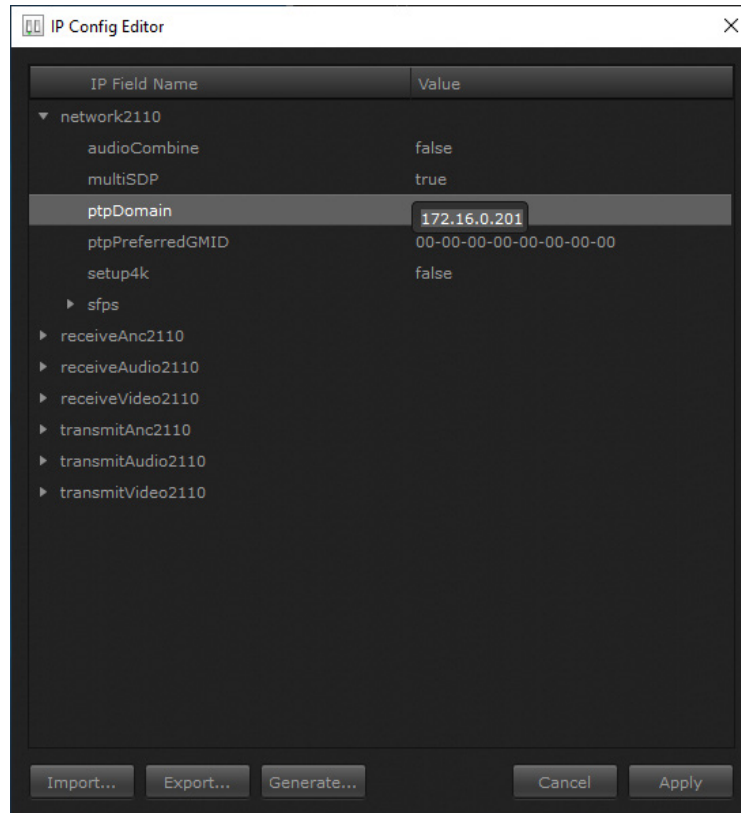

10. Using these values as a starting point, you can now open other data fields in the editor to manually adjust the remaining configuration values as required. When the configuration is complete, click **Apply** to enable the settings for that KONA IP.
11. This JSON file can be named and exported to a shared network location, and then be imported as needed into other KONA IP transmit and receive devices to be used as a starting point for further configuration.

## Transmit/Receive Example

One simple way to test actual operation over the network is to configure two KONA IPs with complimentary settings, as follows:

1. Perform an initial configuration on a KONA IP device as described above, entering a different address. This will be used as the playback device.
2. Import that configuration to a second KONA IP, edit that base SFP address (for example, increment by 100), and swap the RX and TX IP addresses for that second device. These complimentary configurations allow bi-directional transport between the two KONA IPs.

KONA Device	Base SFP	Rx Destination	Tx Remote	Port
KONA IP #1	172.16.45.0	239.0.45.0	239.20.45.0	1000
KONA IP #2	172.16.45.100	239.20.45.0	239.0.45.0	1000

3. You should now be able to open AJA's Control Room application on each computer and test playback and capture.

## AJA NMOS Controls

---

When the tray icon is clicked (on the Mac or right click on Windows) the AJA NMOS application offers a number of options:

- View Log - toggles opening or closing of the log window
- Stop/Start Service - allows the NMOS service to be stopped and restarted without quitting the application
- Enable/Disable Debug Log - enables or disables the generation of debug output to the AjaLogger and the log window
- Enable/Disable DNS Debug - enables or disables additional DNS debug information (independent of Debug Log setting)
- Enable/Disable Verbose Debug - enables or disables additional debug information if the Debug Log setting is enabled
- Select Interface - NMOS only uses one interface to access the registry. If there is only one interface, then that is not a problem. If there is more than one, then if auto is selected, it will automatically choose one based on whether it sees any mDNS messages on one of the interfaces. Otherwise, the interface can be selected.
- Set Registry IP - allows the registry ip address and port to be set manually.
- Quit - causes the NMOS application to exit

## Transmit Redundancy with ST 2110 via ST 2022-7

---

### For JSON Configuration (Transmit only)

---

1. Go into Advanced Ip Config / Generate for JSON
2. Set Tx Remote to the IP address to which you are sending
3. Manually set the frame rate in the frame buffer within AJA Control Panel.

## Guidance for SMPTE ST 2110-23

---

### For JSON Configuration

---

1. Go into Advanced Ip Config / Generate for JSON.
2. When doing this behavior is to now automatically set up for 2K/HD on SFP 1, or 4K/UltraHD across both SFPS.
3. Set Tx Remote to the IP address to which you are sending.
4. On receiving device use this same IP address (i.e. Rx IP address should match your Tx IP address).
5. Un-check follow input on the receiving KONA IP.
6. Manually set the frame rate in the frame buffer within AJA Control Panel.

### For SDPs

---

1. Change the 4K/UHD network settings in the JSON 4K setup from false to true.
2. Un-check follow input.

3. Then just one SDP is entered in capture input 1 and sets automatically for all four streams.
4. Manually change frame buffer on any format change.

# Appendix A – Specifications

---

## KONA IP Tech Specs

---

### Video Formats

---

- (4K)\*\* 4096 x 2160p 23.98, 24, 25, 29.97, 30, 50, 59.94, 60
- (UltraHD)\*\* 3840 x 2160p 23.98, 24, 25, 29.97, 30, 50, 59.94, 60
- (2K) 2048 x 1080p 23.98, 24, 25, 29.97, 30, 50\*, 59.94\*, 60\*
- (2K) 2048 x 1080PsF 23.98, 24, 25
- (HD) 1080p 23.98, 24, 25, 29.97, 30, 50, 59.94, 60
- (HD) 1080PsF 23.98, 24, 25, 29.97, 30
- (HD) 1080i 50, 59.94
- (HD) 720P 50, 59.94, 60
- (SD) 625i 50
- (SD) 525i 59.94

\*SMPTE ST 2110 only

\*\*2SI over IP via ST 2110-23 only

Note: High Frame Rate capabilities are dependent on host system attributes. Not all systems and configurations will support all frame rates.

### Media Transport Interfaces

---

- SMPTE ST 2110 (-10, -20, -21, -23, -30, -40), 2022-6
  - 2x SFP+ Cages - SFPs not included
- Recommended 10GigE SFP+ modules:
  - Arista Networks SFP-10G-SR Compatible 10GBASE-SR
  - Fiberstore SFP-10GSR-85 10G SFP+ 850nm
  - Finisar FTLX1471D3BCL (for single mode 1310nm)
  - Mellanox MFM1T02A-SR 850nm 10G

### Video Input IP

---

- SMPTE ST 2110, 2022-6
  - Single channel\* input available when using ST 2110 or ST 2022-6 to receive 2K/HD
  - 4-channels input available when using ST 2110-23 to receive 4K/UltraHD\*\*
  - ANC support
  - Rx support for Narrow Senders\*\*

\*Capture and simultaneous monitoring is supported up to 2K/HD

\*\*SMPTE ST 2110 only

### Video Output IP

---

- SMPTE ST 2110, 2022-6
  - Single channel\* output available when using ST 2110 or ST 2022-6 to transmit 2K/HD
  - 4-channels output available when using ST 2110-23 to transmit 4K/UltraHD\*\*
  - ANC support
  - Tx support for ST 2022-7 up to 2K/HD
  - Tx support for Narrow Receivers\*\*

\*Capture and simultaneous monitoring is supported up to 2K/HD

\*\*SMPTE ST 2110 only

---

## Video Output Digital

- HDMI v1.4b
  - 30/36-bits/pixel, RGB or YUV, 2.25 Gbps
  - 4K/UltraHD, 2K/HD and SD
  - 2K/HD downsample available when working with 4K/UltraHD via ST 2110-23

---

## HDR

- HDMI: HDR10 Support - HDR Infoframe metadata, compatible with HDMI 2.0a/CTA-861.3
- HDMI: HLG Support - compatible with HDMI 2.0b/CTA-861-G

Note: HDR support is application dependent. Check with your software manufacturer for compatibility.

---

## Audio Input IP

- Up to 16-channel embedded audio, 24-bit per channel, 48 kHz synchronous

---

## Audio Output IP

- Up to 16-channel embedded audio, 24-bit per channel, 48 kHz synchronous

---

## Audio Output Digital

- 8-channel HDMI embedded audio, 48 kHz sample rate, synchronous

---

## Downstream Keyer

- Supports graphics up to 2K/HD with alpha channel over video, matte or framebuffer, or framebuffer content over incoming video or matte

---

## Reference and LTC I/O

- 1x BNC assignable to Reference video or LTC input

---

## Reference

- Analog Color Black (1V) or Composite Sync (2 or 4V) or HD Tri-Level Sync (1V)
- Reference input is terminated into 75 ohms when Genlock is set to Ref In
- Applicable in SMPTE ST 2022-6/7 environments

---

## Discovery, Registration and Control

- NMOS Tx/Rx support for SMPTE ST 2110 according to standards IS-04 v1.3 and IS-05 v1.1
  - Applicable in SMPTE ST 2110 environments
- LLDP

---

## IP Clock

- PTP support compliant with PTP PTPv2 / IEEE 1588-2008
- Applicable in SMPTE ST 2110 environments

---

## Electrical Interface

- 8-lane PCIe 2.0

---

## Size (w x d x h)

- 0.75" x 8.25" x 5.0" (19.05 x 209.55 x 127.00 mm)

## Weight

---

- 0.7 lb (0.4 kg)

## Power

---

- 25W typical, 27W maximum

## Environment

---

- Safe Operating Temperature Range: 0 to 40 C (32 to 104 F)
- Safe Storage Temperature (Power OFF): -40 to 60 C (-40 to 140 F)
- Operating Relative Humidity: 10-90% noncondensing
- Operating Altitude: <3,000 meters (<10,000 feet)

# Appendix B – Safety & Compliance

---

## Federal Communications Commission (FCC) Compliance Notices

---

### Class B Interference Statement

---

This equipment has been tested and found to comply with the limits for a Class B digital device, pursuant to Part 15, Subpart B of the FCC Rules. These limits are designed to provide reasonable protection against harmful interference in a residential installation. This equipment generates, uses, and can radiate radio frequency energy and, if not installed and used in accordance with the instructions, may cause harmful interference to radio communications. However, there is no guarantee that interference will not occur in a particular installation. If this equipment does cause harmful interference to radio or television reception, which can be determined by turning the equipment off and on, the user is encouraged to try to correct the interference by one or more of the following measures:

- Reorient or relocate the receiving antenna.
- Increase the separation between the equipment and receiver.
- Connect the equipment into an outlet on a circuit different from that to which the receiver is connected.
- Consult the dealer or an experienced radio/TV technician for help.

### FCC Caution

---

This device complies with Part 15 of the FCC Rules. Operation is subject to the following two conditions: (1) This device may not cause harmful interference, and (2) this device must accept any interference received, including interference that may cause undesired operation.

## Canadian ICES Statement

---

### Canadian Department of Communications Radio Interference Regulations

This digital apparatus does not exceed the Class B limits for radio-noise emissions from a digital apparatus as set out in the Radio Interference Regulations of the Canadian Department of Communications. This Class B digital apparatus complies with Canadian ICES-003.

### Règlement sur le brouillage radioélectrique du ministère des Communications

Cet appareil numérique respecte les limites de bruits radioélectriques visant les appareils numériques de classe B prescrites dans le Règlement sur le brouillage radioélectrique du ministère des Communications du Canada. Cet appareil numérique de la Classe B est conforme à la norme NMB-003 du Canada.

## European Union and European Free Trade Association (EFTA) Regulatory Compliance

---

This equipment may be operated in the countries that comprise the member countries of the European Union and the European Free Trade Association. These countries, listed in the following paragraph, are referred to as The European Community throughout this document:

AUSTRIA, BELGIUM, BULGARIA, CYPRUS, CZECH REPUBLIC, DENMARK, ESTONIA, FINLAND, FRANCE, GERMANY, GREECE, HUNGARY, IRELAND, ITALY, LATVIA, LITHUANIA, LUXEMBOURG, MALTA, NETHERLANDS, POLAND, PORTUGAL, ROMANIA, SLOVAKIA, SLOVENIA, SPAIN, SWEDEN, UNITED KINGDOM, ICELAND, LICHTENSTEIN, NORWAY, SWITZERLAND

### Declaration of Conformity

---

Marking by this symbol indicates compliance with the Essential Requirements of the EMC Directive of the European Union 2014/30/EU.



This equipment meets the following conformance standards:

Safety

EN 60065: 2014 (T-Mark License),

IEC 60065: 2014, (CB Scheme Report/Certificate)

Additional licenses issued for specific countries available on request.

Emissions

EN 55032: 2012 + AC: 2013, CISPR 32: 2015

EN 61000-3-2: 2014, EN 61000-3-3: 2013

Immunity

EN 55103-2: 2009, EN 61000-4-2:2009, EN 61000-4-3:2006 +A1:2008 +A2:2010,

EN 61000-4-4:2004+ A1:2010, EN 61000-4-5:2006, EN 61000-4-6:2009,

EN 61000-4-11:2004

Environments: E2, E3 and E4

The product is also licensed for additional country specific standards as required for the International Marketplace.



**Warning!** This is a Class B product. In a domestic environment, this product may cause radio interference, in which case, the user may be required to take appropriate measures.

**Achtung!** Dieses ist ein Gerät der Funkstörgrenzwertklasse B. In Wohnbereichen können bei Betrieb dieses Gerätes Rundfunkstörungen auftreten, in welchen Fällen der Benutzer für entsprechende Gegenmaßnahmen verantwortlich ist.

**Attention!** Ceci est un produit de Classe B. Dans un environnement domestique, ce produit risque de créer des interférences radioélectriques, il appartiendra alors à l'utilisateur de prendre les mesures spécifiques appropriées.

Recycling Notice



This symbol on the product or its packaging indicates that this product must not be disposed of with your other household waste. Instead, it is your responsibility to dispose of your waste equipment by handing it over to a designated collection point for the recycling of waste electrical and electronic equipment. The separate collection and recycling of your waste equipment at the time of disposal will help conserve natural resources and ensure that it is recycled in a manner that protects human health and the environment. For more information about where you can drop off your waste for recycling, please contact your local authority, or where you purchased your product.

Korea KCC Compliance Statement

<p>B급 기기 (가정용 방송통신기자재)</p> <p>Class B (Broadcasting Communication Equipment for Home Use)</p>	<p>이 기기는 가정용(B급) 전자파적합기기로서 주로 가정에서 사용하는 것을 목적으로 하며, 모든 지역에서 사용할 수 있습니다.</p> <p>As an electromagnetic wave equipment for home use (Class B), this equipment is intended to use mainly for home use and may be used in all areas.</p>
---	---

## Taiwan Compliance Statement

警告使用者：  
這是甲類的資訊產品，在居住的環境中使用時，可能會造成射頻干擾，在這種情況下，使用者會被要求採取某些適當的對策。

This is a Class B product based on the standard of the Bureau of Standards, Metrology and Inspection (BSMI) CNS 13438, Class B. In a domestic environment this product may cause radio interference in which case the user may be required to take adequate measures.

## Japan Compliance Statement

この装置は、クラスB情報技術装置です。この装置は、家庭環境で使用することを目的としていますが、この装置がラジオやテレビジョン受信機に近接して使用されると、受信障害を引き起こすことがあります。  
取扱説明書に従って正しい取り扱いをして下さい。 VCCI-B

This is a Class B product based on the standard of the VCCI Council (VCCI 32: 2016). If this is used near a radio or television receiver in a domestic environment, it may cause radio interference. Install and use the equipment according to the instruction manual.

## Translated Warning and Caution Messages

The following caution statements, warning conventions, and warning messages apply to this product and manual.



Warning Symbol



Caution Symbol

## Before Operation Please Read These Instructions



**Warning!** Read and follow all warning notices and instructions marked on the product or included in the documentation.

**Avertissement!** Lisez et conformez-vous à tous les avis et instructions d'avertissement indiqués sur le produit ou dans la documentation.

**Warnung!** Lesen und befolgen Sie die Warnhinweise und Anweisungen, die auf dem Produkt angebracht oder in der Dokumentation enthalten sind.

**¡Advertencia!** Lea y siga todas las instrucciones y advertencias marcadas en el producto o incluidas en la documentación.

**Aviso!** Leia e siga todos os avisos e instruções assinalados no produto ou incluídos na documentação.

**Avviso!** Leggere e seguire tutti gli avvisi e le istruzioni presenti sul prodotto o inclusi nella documentazione.



**Warning!** Do not use this device near water and clean only with a dry cloth.

**Avertissement!** N'utilisez pas cet appareil près de l'eau et nettoyez-le seulement avec un tissu sec.

**Warnung!** Das Gerät nicht in der Nähe von Wasser verwenden und nur mit einem trockenen Tuch säubern.

**¡Advertencia!** No utilice este dispositivo cerca del agua y límpielo solamente con un paño seco.

**Aviso!** Não utilize este dispositivo perto da água e limpe-o somente com um pano seco.

**Avviso!** Non utilizzare questo dispositivo vicino all'acqua e pulirlo soltanto con un panno asciutto.



**Warning!** Do not block any ventilation openings. Install in accordance with the manufacturer's instructions.

**Avertissement!** Ne bloquez aucune ouverture de ventilation. Suivez les instructions du fabricant lors de l'installation.

**Warnung!** Die Lüftungsöffnungen dürfen nicht blockiert werden. Nur gemäß den Anweisungen des Herstellers installieren.

**¡Advertencia!** No bloquee ninguna de las aberturas de la ventilación. Instale de acuerdo con las instrucciones del fabricante.

**Aviso!** Não obstrua nenhuma das aberturas de ventilação. Instale de acordo com as instruções do fabricante.

**Avviso!** Non ostruire le aperture di ventilazione. Installare in conformità con le istruzioni del fornitore.



**Warning!** Do not install near any heat sources such as radiators, heat registers, stoves, or other apparatus (including amplifiers) that produce heat.

**Avertissement!** N'installez pas l'appareil près d'une source de chaleur telle que des radiateurs, des bouches d'air de chauffage, des fourneaux ou d'autres appareils (amplificateurs compris) qui produisent de la chaleur.

**Warnung!** Nicht in der Nähe von Wärmequellen wie Heizkörpern, Heizregistern, Öfen oder anderen Wärme erzeugenden Geräten (einschließlich Verstärkern) aufstellen.

**¡Advertencia!** No instale cerca de fuentes de calor tales como radiadores, registros de calor, estufas u otros aparatos (incluidos amplificadores) que generan calor.

**Aviso!** Não instale perto de nenhuma fonte de calor tal como radiadores, saídas de calor, fogões ou outros aparelhos (incluindo amplificadores) que produzam calor.

**Avviso!** Non installare vicino a fonti di calore come termosifoni, diffusori di aria calda, stufe o altri apparecchi (amplificatori compresi) che emettono calore



**Warning!** Unplug this device during lightning storms or when unused for long periods of time.

**Avertissement!** Débranchez cet appareil pendant les orages avec éclairs ou s'il est inutilisé pendant de longues périodes.

**Warnung!** Das Gerät ist bei Gewitterstürmen oder wenn es über lange Zeiträume ungenutzt bleibt vom Netz zu trennen.

**¡Advertencia!** Desenchufe este dispositivo durante tormentas eléctricas o cuando no se lo utilice por largos periodos del tiempo.

**Aviso!** Desconecte este dispositivo da tomada durante trovoadas ou quando não é utilizado durante longos periodos de tempo.

**Avviso!** Utilizzare soltanto i collegamenti e gli accessori specificati e/o venduti dal produttore, quali il treppiedi e l'esoscheletro.



**Warning!** Only use attachments and accessories specified and/or sold by the manufacturer.

**Avertissement!** Utilisez seulement les attaches et accessoires spécifiés et/ou vendus par le fabricant.

**Warnung!** Verwenden Sie nur Zusatzgeräte und Zubehör angegeben und / oder verkauft wurde durch den Hersteller.

**¡Advertencia!** Utilice solamente los accesorios y conexiones especificados y/o vendidos por el fabricante.

**Aviso!** Utilize apenas equipamentos/acessórios especificados e/ou vendidos pelo fabricante.

**Avviso!** Utilizzare soltanto i collegamenti e gli accessori specificati e/o venduti dal produttore.



**Warning!** Refer all servicing to qualified service personnel. Servicing is required when the device has been damaged in any way, such as power-supply cord or plug is damaged, liquid has been spilled or objects have fallen into the device, the device has been exposed to rain or moisture, does not operate normally, or has been dropped.

**Avertissement!** Référez-vous au personnel de service qualifié pour tout entretien. L'entretien est exigé quand l'appareil a été endommagé de quelque manière que ce soit, par exemple lorsque le cordon d'alimentation ou la prise sont endommagés, que du liquide a été versé ou des objets sont tombés dans l'appareil, que l'appareil a été exposé à la pluie ou à l'humidité, ne fonctionne pas normalement ou est tombé.

**Warnung!** Das Gerät sollte nur von qualifizierten Fachkräften gewartet werden. Eine Wartung ist fällig, wenn das Gerät in irgendeiner Weise beschädigt wurde, wie bei beschädigtem Netzkabel oder Netzstecker, falls Flüssigkeiten oder Objekte in das Gerät gelangen, das Gerät Regen oder Feuchtigkeit ausgesetzt wurde, nicht ordnungsgemäß funktioniert oder fallen gelassen wurde.

**¡Advertencia!** Consulte al personal calificado por cuestiones de reparación. El servicio de reparación se requiere cuando el dispositivo ha recibido cualquier tipo de daño, por ejemplo cable o espigas dañadas, se ha derramado líquido o se han caído objetos dentro del dispositivo, el dispositivo ha sido expuesto a la lluvia o humedad, o no funciona de modo normal, o se ha caído.

**Aviso!** Remeta todos os serviços de manutenção para o pessoal de assistência qualificado. A prestação de serviços de manutenção é exigida quando o dispositivo foi danificado mediante qualquer forma, como um cabo de alimentação ou ficha que se encontra danificado/a, quando foi derramado líquido ou caíram objectos sobre o dispositivo, quando o dispositivo foi exposto à chuva ou à humidade, quando não funciona normalmente ou quando foi deixado cair.

**Avviso!** Fare riferimento al personale qualificato per tutti gli interventi di assistenza. L'assistenza è necessaria quando il dispositivo è stato danneggiato in qualche modo, ad esempio se il cavo di alimentazione o la spina sono danneggiati, è stato rovesciato del liquido è stato rovesciato o qualche oggetto è caduto nel dispositivo, il dispositivo è stato esposto a pioggia o umidità, non funziona correttamente o è caduto



**Warning!** Do not defeat the safety purpose of the polarized or grounding-type plug. A polarized plug has two blades with one wider than the other. A grounding type plug has two blades and a third grounding prong. The wide blade or the third prong are provided for your safety. If the provided plug does not fit into your outlet, consult an electrician for replacement of the obsolete outlet.

**Avertissement!** La sécurité de la prise polarisée ou de la prise de type mise à la terre ne doit en aucun cas être empêchée de fonctionner. Une prise polarisée a deux broches, l'une étant plus large que l'autre. Une prise de type mise à la terre a deux broches et une troisième broche pour la mise à la terre. La broche large ou la troisième broche sont fournies pour votre sécurité. Si la prise fournie ne s'insère pas dans votre prise femelle, consultez un électricien pour le remplacement de la prise femelle obsolète.

**Warnung!** Der Sicherheitszweck des gepolten bzw. Schukosteckers ist zu berücksichtigen. Ein gepolter Stecker verfügt über zwei Pole, von denen einer breiter als der andere ist. Ein Schukostecker verfügt neben den zwei Polen noch über einen dritten Pol zur Erdung. Der breite Pol bzw. der Erdungspol dienen der Sicherheit. Wenn der zur Verfügung gestellte Stecker nicht in Ihren Anschluss passt, konsultieren Sie einen Elektriker, um den veralteten Anschluss zu ersetzen.

**¡Advertencia!** No eche por tierra la finalidad del tipo de enchufe polarizado con conexión a tierra. Un enchufe polarizado tiene dos espigas, una más ancha que la otra. Un enchufe con conexión a tierra tiene dos espigas iguales y una tercera espiga que sirve para la conexión a tierra. La espiga ancha, o la tercera espiga, sirven para su seguridad. Si el enchufe suministrado no encaja en el tomacorriente, consulte con un electricista para reemplazar el tomacorriente obsoleto.

**Aviso!** Não anule a finalidade da segurança da ficha polarizada ou do tipo ligação terra. Uma ficha polarizada tem duas lâminas sendo uma mais larga do que a outra. Uma ficha do tipo de ligação à terra tem duas lâminas e um terceiro terminal de ligação à terra. A lâmina larga ou o terceiro terminal são fornecidos para sua segurança. Se a ficha fornecida não couber na sua tomada, consulte um electricista para a substituição da tomada obsoleta.

**Avviso!** Non compromettere la sicurezza della spina polarizzata o con messa a terra. Una spina polarizzata ha due spinotti, di cui uno più largo. Una spina con messa a terra ha due spinotti e un terzo polo per la messa a terra. Lo spinotto largo o il terzo polo sono forniti per motivi di sicurezza. Se la spina fornita non si inserisce nella presa di corrente, contattare un elettricista per la sostituzione della presa obsoleta.



**Warning!** Since the Mains plug is used as the disconnection for the device, it must remain readily accessible and operable.

**Avertissement!** Puisque la prise principale est utilisée pour débrancher l'appareil, elle doit rester aisément accessible et fonctionnelle.

**Warnung!** Da der Netzstecker als Trennvorrichtung dient, muss er stets zugänglich und funktionsfähig sein.

**¡Advertencia!** Puesto que el enchufe de la red eléctrica se utiliza como dispositivo de desconexión, debe seguir siendo fácilmente accesible y operable.

**Aviso!** Dado que a ficha principal é utilizada como a desconexão para o dispositivo, esta deve manter-se prontamente acessível e funcional.

**Avviso!** Poiché il cavo di alimentazione viene usato come dispositivo di sconnessione, deve rimanere prontamente accessibile e operabile.



**Warning!** Protect the power cord from being walked on or pinched particularly at plugs, convenience receptacles, and the point where they exit from the device.

**Avertissement!** Protégez le cordon d'alimentation pour que l'on ne marche pas dessus ou qu'on le pince, en particulier au niveau des prises mâles, des réceptacles de convenance, et à l'endroit où il sort de l'appareil.

**Warnung!** Vermeiden Sie, dass auf das Netzkabel getreten oder das Kabel geknickt wird, insbesondere an den Steckern, den Steckdosen und am Kabelausgang am Gerät.

**¡Advertencia!** Proteja el cable de energía para que no se le pise ni apriete, en especial cerca del enchufe, los receptáculos de conveniencia y el punto del que salen del equipo.

**Aviso!** Proteja o cabo de alimentação de ser pisado ou de ser comprimido particularmente nas fichas, em tomadas de parede de conveniência e no ponto de onde sai do dispositivo.

**Avviso!** Proteggere il cavo di alimentazione in modo che nessuno ci cammini sopra e che non venga schiacciato soprattutto in corrispondenza delle spine e del punto in cui esce dal dispositivo.



**Warning!** Disconnect the external AC power supply line cord(s) from the mains power before moving the unit.

**Avertissement!** Retirez le ou les cordons d'alimentation en CA de la source d'alimentation principale lorsque vous déplacez l'appareil.

**Warnung!** Trennen Sie die Wechselstrom-Versorgungskabel vom Netzstrom, bevor Sie das Gerät verschieben.

**¡Advertencia!** Cuando mueva la unidad desenchufe de la red eléctrica el/los cable(s) de la fuente de alimentación CA tipo brick.

**Advertência!** Remova os cabos CA de alimentação brick da rede elétrica ao mover a unidade.

**Avvertenza!** Scollegare il cavo dell'alimentatore quando si sposta l'unità.

# Warranty and Liability Information

---

## Limited Warranty on Hardware

---

AJA Video Systems, Inc. (AJA Video) warrants that the hardware product, not including storage modules or software components, will be free from defects in materials and workmanship for a period of three years from the date of purchase. AJA Video warrants that the storage modules provided as part of the hardware product will be free from defects in materials and workmanship for a period of one year from the date of purchase. AJA Video provides a separate software warranty as part of the license agreement applicable to software components.

If the Customer brings a valid claim under this limited warranty for a hardware product or storage module (hereafter, a "product") during the applicable warranty period, AJA Video will, at its sole option and as the Customer's sole remedy for breach of the above warranty, provide one of the following remedies:

- Repair or facilitate the repair the product within a reasonable period of time, free of charge for parts and labor.
- Replace the product with a direct replacement or with a product that performs substantially the same function as the original product.
- Issue a refund of the original purchase price less depreciation to be determined based on the age of the product at the time remedy is sought under this limited warranty.

To obtain service under this warranty, the Customer must notify AJA Video of the defect before expiration of the warranty period and make suitable arrangements for the performance of service by contacting AJA Video support through the channels set forth on the support contacts web page at <https://www.aja.com/support>.

Except as stated, the Customer shall bear all shipping, packing, insurance and other costs, excluding parts and labor, to effectuate repair. Customer shall pack and ship the defective product to a service center designated by AJA Video, with shipping charges prepaid. AJA Video shall pay to return the product to Customer, but only if to a location within the country in which the AJA Video service center is located. SOME JURISDICTIONS DO NOT ALLOW THE EXCLUSION OF IMPLIED WARRANTIES OR LIMITATIONS ON APPLICABLE STATUTORY RIGHTS OF A CONSUMER, SO SOME OR ALL OF THE TERMS OF THIS PARAGRAPH MAY NOT APPLY TO YOU.

## Limitation of Liability

---

Under no circumstances shall AJA video BE LIABLE IN ANY WAY FOR ANY LOST, CORRUPTED OR DESTROYED DATA, FOOTAGE OR WORK, OR FOR ANY OTHER INDIRECT, SPECIAL, INCIDENTAL OR CONSEQUENTIAL DAMAGES OR LOST PROFITS, OR FOR ANY THIRD PARTY CLAIM, IN CONNECTION WITH THE PRODUCT, WHETHER RESULTING FROM DEFECTS IN THE PRODUCT, SOFTWARE OR HARDWARE FAILURE, OR ANY OTHER CAUSE WHATSOEVER, EVEN IF AJA VIDEO HAS BEEN ADVISED OF THE POSSIBILITY OF SUCH DAMAGES. AJA VIDEO'S LIABILITY IN CONNECTION WITH THE PRODUCT SHALL UNDER NO CIRCUMSTANCES EXCEED THE PURCHASE PRICE PAID FOR THE PRODUCT. The foregoing limitations apply even if any remedy set forth in this LIMITED WARRANTY fails of its essential purpose. SOME JURISDICTIONS DO NOT ALLOW THE LIMITATION OF LIABILITY FOR PERSONAL INJURY, OR OF INCIDENTAL OR CONSEQUENTIAL DAMAGES, SO SOME OR ALL OF THE TERMS OF THIS PARAGRAPH MAY NOT APPLY TO YOU.

## Governing Law and Language; Your Rights

---

This limited warranty is the only warranty provided by AJA Video on the hardware product. It supersedes all prior or contemporaneous understandings regarding such subject matter. No amendment to or modification of this warranty will be binding unless in writing and signed by AJA Video. The laws of the State of California, USA will govern this warranty and any dispute arising from it. Any translation of this Agreement is intended for convenience and to meet local requirements and in the event of a dispute between the English and any non-English versions, the English version of this warranty will govern. This limited warranty gives you specific legal rights and you may have other rights that vary from jurisdiction to jurisdiction, some of which are noted above.

# Index

## Symbols

- 2SI Alignment 27
- 3G Transport 31
- 3rd-Party Plugins 8
- 2022-6 5
- 2022-7 6
- 2022-7 Operation 41
- 2110 6

## A

- Advanced Button 54
- AJA Agent is not running 21
  - Restart Services 21
- AJA Control Panel 8
- AJA Control Room 8
- AJA Device Drivers 8
- AJA NMOS App 8
- AJA NMOS Controls 62
- AJA Software & Utilities 7
- AJA Support 2
- AJA System Test 8, 13
- Apply
  - s2110 Mode 57
- Audio Ch 31
- Audio Input 29
- Audio Mixer Capture Monitor Tab 39
- Audio Mixer Playback Monitor Tab 38
- Audio Mixer Screen 37
- Audio Out 45
- Audio Setup Screen 36

## B

- Block Diagram Area 19
- BMP Format 18

## C

- Cable Connections 14
- Capture Formats 18
- Capture Mode 19
- Ch Map 30
- Colorimetry 33
- Color Space 31, 32, 35
- Controlling Application 21
- Controlling Application Format Selection 21
- Control Panel 8, 18
  - Block Diagram Area 19
  - Framebuffer 20
  - Input/Output Icon 20
  - UI Colors 20
  - User Interface 19
- Control Panel Operation
  - s2110 Mode 52
- Control Panel Restart Services 21
- Control Room 8
- Control Screen

- Standard Mode 26

## D

- Damage in Shipping 13
- Default Preferences 22
- Default State 26
- Delete Preset 50
- Dest IP Addr 42
- Dest IP Addr 2 43
- Dest Port 42
- Dest Port 2 43
- Device Drivers 8
- Device Format 20
- Digital Primaries 34
- Disk Storage Methods 9
- Display Mastering Luminance 34
- Downstream Keyer Mode 45
- Downstream Keyer Screen 44
- DPX Format 18

## E

- Enable 2022-7 40
- Enable Checkbox 44
- Erase all Prefs 51
- Export 56, 57

## F

- Features
  - KONA IP 10
- Firmware Screen 51
- Follow Input 29
- Follow Input Settings
  - s2110 Mode 53
- Foreground Pre-Multiplied 45
- Format 28
- Format Screen
  - Standard Mode 28
- Framebuffer
  - Control Panel UI 20

## G

- Gamma 35
- Gateway Address 40
- General Operation
  - s2110 Mode 52
- Generate 57
  - s2110 Mode 58
- Generate Window
  - s2110 Mode 58
- Global Preference 23
- Global Preference File Location 23
- Graphic File Load 46

## H

- HDMI Output 11
- HDMI Screen

- Standard Mode 31

- HDR Capture 33
- HDR Mode 34
- HDR Screen 33
- Hold Last App 27

## I

- Import 57
- Information Screen
  - Standard Mode 52
- Input/Output Icon 20
- Input Passthrough 26
- Input Select Screen
  - Standard Mode 29
- Inserting KONA Card 16
  - Installation
    - KONA Card 14
    - Software 16
- IP Config Screen
  - s2110 Mode Capture Tab 54
  - s2110 Mode Editor Window 57
  - s2110 Mode Playback Tab 56
  - S2110 Mode Status Tab 53
- IP Input Screen 42
- IP Media Transport
  - Descriptions 5
- IP Network Screen 40, 41
- IP Output Screen 43

## K

- KONA Card
  - Inserting 16
  - Installation 14
  - Removing 16
- KONA IP Features 10
- KONA IP Firmware
  - Types 17

## L

- Load Preset 50
- Local IP Address 40
- Local MAC Address 40
- Local Preference 22
- Local Preference File 22
- Luminance 33
- LUT File
  - Format Specification 48
  - Uploading 48
- LUT Screen 46

## M

- Match Checkbox 43
- Matte Color 45
- Maximum Content Light Level (CLL) 34
- Maximum Frame Average Light Level (FALL) 34

- Modes of Operation 18
- Monitor Channels 36
- Monitor Level 36
- Multicast 17
- Multiple AJA Devices 24
- MXF Format 18

## N

- Network Requirements 8
- NMOS 6

## O

- Opacity 46
- Operating Modes 18
- Output Select Screen 30
- Overview 5

## P

- Pixel Format 28
- Playback Mode 18
- Playback Source Selection 38
- Preference 22
- Preference File Location
  - Default Global 23
- Preset
  - Delete 50
  - Load 50
  - s2110 Mode 53
  - Save 50
- Preset Files Storage Location 22, 50
- Presets 22
- Presets Screen 50
- Primary Format 28
- Primary Output
  - HDMI 31
- Progressive Pref 35
- Protocol 31
- PTP Information 54

## Q

- QuickTime Format 18

## R

- Reference Clock 11
- Refresh 55
- Removing KONA Card 16
- Reset
  - s2110 Mode 53
- Reset to Default 51
- Restart Services
  - Control Panel 21
- RGB Range 28, 31, 32

## S

- s2022 Firmware 17
- Save Preset 50
- SDI Color Sp 29
- SDI RGB Rng 29
- SDP 55, 56

- Select HDMI Primary Output 31
- Set
  - s2110 Mode 55
- Set Button 41
- SFP Cage 11
- SFP Local IP 54
- SFP Module 11, 16
- Shipping Box Contents 13
- Snapshot 50
- Software 7
- Software Installation 16
- Source
  - Video Input 29
- ST 2110 Configuration
  - Advanced 59
- Subnet Mask 40
- System Connections
  - KONA IP 15
- System Requirements 9
- System Test 8

## T

- Technical Support 2
- Test Pattern 27
- TGA Format 18
- Thunderbolt PCIe External Chassis 14
- Timecode Screen 49
- Timecode Source 49
- Transfer 33
- Transferring Saved Presets 50

## U

- Unicast 17
- User Bits 49
- Utilities 7

## V

- VANC Checkbox 35
- Video+Key 30
- Video Input 29
- Video Setup 35
- Video Setup Screen 35