

KONA IP25

Transport, Capture, Display



Installation and Operation Manual

Version 17.6
Published November 7, 2025



Notices

Trademarks

AJA® and Because it matters.® are registered trademarks of AJA Video Systems, Inc. for use with most AJA products. AJA™ is a trademark of AJA Video Systems, Inc. for use with recorder, router, software and camera products. Because it matters.™ is a trademark of AJA Video Systems, Inc. for use with camera products.

Corvid Ultra®, Io®, Ki Pro®, KONA®, KUMO®, ROI® and T-Tap® are registered trademarks of AJA Video Systems, Inc.

AJA Control Room™, KiStor™, Science of the Beautiful™, TruScale™, V2Analog™ and V2Digital™ are trademarks of AJA Video Systems, Inc.

All other trademarks are the property of their respective owners.

Copyright

Copyright © 2025 AJA Video Systems, Inc. All rights reserved. All information in this manual is subject to change without notice. No part of the document may be reproduced or transmitted in any form, or by any means, electronic or mechanical, including photocopying or recording, without the express written permission of AJA Video Systems, Inc.

Contacting AJA Technical Support or Sales

Please have all pertinent information at hand prior to contacting AJA support or sales.

Support Telephone: +1.530.271.3190

Support Website: <https://www.aja.com/support/contact>

Support Email: support@aja.com

Sales Email: sales@aja.com

Shipping Address: AJA Video Systems
180 Litton Drive
Grass Valley, CA 95945, USA

Contents

Notices	2
Trademarks	2
Copyright	2
Contacting AJA Technical Support or Sales	2
Chapter 1 – Introduction	5
Overview	5
KONA IP25 Features	5
AJA Software & Utilities	7
Network Requirements	8
System Requirements	9
Disk Storage Methods	9
KONA IP25 Connectors	9
Chapter 2 – Installation	10
Installation Overview	10
Third Party Software Support	10
AJA System Test Application	10
KONA IP25 Card Access for Configuration and Control	10
Unpacking	13
Shipping Box Contents	13
Installing KONA Cards	13
Cabling the System	14
KONA IP25 Cable Connections	14
Installing KONA IP25 Software	16
Download	16
Software Package Installation and Re-installation	16
macOS Installations	16
KONA IP25 Firmware Installation	16
Chapter 3 – Operation	17
Using KONA with Professional Video /Audio Software	17
Capture Formats	17
AJA Control Panel Overview	17
AJA Control Panel Operating Modes	17
AJA Control Panel User Interface	18
Presets	20
Default Preferences	20
Controlling Application	22
Using Multiple AJA Products	22
Function Screens	23
Control Panel Operation	24
Control Screen	24
Format Screen	25
Input Select Screen	26
Output Select Screen	28
HDR Screen	29
Video Setup Screen	30
Audio Mixer Screens	32
Audio Mixer Capture Monitor Tab	33
Audio Mixer Playback Monitor Tab	34
DS Keyer Tab	35
LUT Screen	37
Presets Screen	40
Info Screen	41
IP Config	42
Inputs Tab	42
Outputs Tab	48
Network Tab	51

Global CTRL Tab	53
PTP Tab	54
System Tab	55
Firmware Tab	56
Statistics Tab	56
Appendix A – Specifications	58
KONA IP25 Tech Specs	58
Appendix B – Safety & Compliance.	61
3 Year Warranty and Liability Information.	68
AJA Software License Agreement.	69
Index.	72

Chapter 1 – Introduction



Overview

KONA IP25 is a powerful video and audio I/O card for professional IP based workflows. As part of AJA's industry leading KONA line of PCIe capture and playback cards, KONA IP25 works seamlessly with the most popular creative software applications, such as Adobe Premiere Pro, Apple FCP, and Avid Media Composer.

Designed as a flexible platform with support for SMPTE ST 2110 (referred to as ST 2110 elsewhere in this manual) uncompressed IP video/audio workflows, KONA IP25 brings the highest quality UltraHD and HD video and audio over IP to computers running Mac, Windows, or Linux Operating Systems.

KONA IP25 is also supported through the very same SDK as the rest of the KONA family, making it straight forward for developers to make the transition to Video over IP.

KONA IP25 Features

KONA IP25 is designed as a platform with the flexibility to support different uncompressed IP requirements at the highest quality for UltraHD and HD video and audio over IP for host systems running Mac, Linux, or Windows Operating Systems.

Video Formats

See "[Appendix A Specifications](#)" on page 58 for a listing of supported video formats.

Physical Connection for IP Video

- 2 x 10 or 25 GigE Ethernet SFP28 Cages - SFP modules not included.

Supported SFP Models

- AJA tests common SFPs in the market but does not make specific recommendations for SFP models. AJA has tested several SFP models from

FS.com, running Arista firmware, with good success. It is the customers' responsibility to ensure the selected SFP models are validated in their systems.

- Ensure compatible SFPs are used on both ends of a fiber.
- Be sure your SFP brand and speed is supported by your Ethernet Switch.

IMPORTANT: Ethernet speeds must match: 25GbE must feed 25GbE, 10GbE must feed 10GbE. Multi-rate 10/25GbE SFPs can be used but ensure the speed is set correctly at each end.

- 25GBASE-SR SFPs (SR => Short range) use 850nm wavelength over Multimode fiber up to 100m of OM4 fiber (70m of OM3).
- 25GBASE-LR SFPs (LR => Long range) use 1310nm wavelength over Single Mode fiber up to 10km.

IMPORTANT: Only fiber SFPs are supported. Direct Attach Copper (DAC) are NOT supported. Other options exist so be sure to match SFP capabilities with the correct fiber type.

NOTE: KONA IP25 speed must be set manually in the UI. It does NOT support auto-negotiation.

Inputs and Outputs

- KONA IP25 ships with firmware for ST 2110 operation.
- For ST 2022-7 operation, a second SFP is used for redundant transport of the signals.

PTP Timing

- PTP (Precision Time Protocol) Timing is supported.

ST 2110 Support

The KONA IP25 supports the transport of uncompressed video (up to 4K DCI), digital audio, and metadata streams over a network. These video, audio, and ancillary streams can be sent and received independently.

A new KONA IP25 must be configured before operation. Once initially configured, that KONA IP25 can be set to receive JSON or SDP information, which completes that device's configuration for a specific workflow task (sending and/or receiving video, audio, and ancillary streams over the network).

Because of the complexity of setting up IP configurations for ST 2110 operation, IT experts at your facility may have created a set of files you can use for quick and easy KONA IP25 re-configuration. A shared network location or other method may also be established to hold these files, to ensure easy access to the correct configuration files for various workflows.

Unicast and Multicast Support

KONA IP25 supports both unicast and multicast operation. Unicast operation is point to point, from one sender to one receiver. Multicast operation is from one sender to possibly multiple receivers. In both cases, the sender transmits media on the network, and receivers access the media over the network using the sender's IP address. Compatible IP addresses are required for each type of operation. These network settings filter the IP addresses so the information is sent successfully to the desired receiver(s).

IMPORTANT: Proper network configuration settings vary, depending on your particular network environment. Because the process can be complicated, you should always consult with your facility's IP or Networking Engineering department before configuring KONA IP25 network settings.

NMOS

NMOS (Network Media Open Specification) is a mechanism for providing discovery, registration and control in ST 2110 environments. KONA IP25 supports automatic discovery and control of IP devices on the network via NMOS IS-04 and IS-05.

Generally, NMOS works as follows:

- When KONA IP25 starts up, it actively scans the network for an NMOS registry using MDNS/DNS. If found, the NMOS registry is informed who the KONA IP25 device is, and its capabilities.
- If during startup the NMOS registry is not found, KONA IP25 continues to announce its presence via MDNS so that it can later be discovered.

KONA IP25 has NMOS disabled by default and is discoverable and controllable by various IP routing and control systems (e.g. Imagine, LAWO, Sony). Discovery, registration and network control are not part of ST 2110 but are specified by AMWA NMOS. Two parts of this standard are IS-04 Discovery and Registration and IS-05 Connection Management.

See "[Global CTRL Tab](#)" on page 53 for additional NMOS details.

Ember+

Ember+ is a control protocol defined by the Lawo Group, allowing communication between two endpoints: a data provider (typically a device exposing a set of controllable parameters) and a consumer (typically a monitoring system). The Ember+ specification consists of three parts:

- Glow: The data schema defining the data types used to convey Ember+ information.
- EmBER: The encoding used to store instances of the Glow-defined types.
- S101: The framing protocol used to transmit EmBER encoded data.

The Ember+ specification is available in the following location: <https://github.com/Lawo/ember-plus/blob/master/documentation/Ember%2B%20Documentation.pdf>

To obtain the latest Ember+ release, refer to <https://github.com/Lawo/ember-plus/releases>

See "[Global CTRL Tab](#)" on page 53 for additional Ember+ details.

AJA Software & Utilities

AJA's KONA software and hardware were developed for powerful integrated video/audio capture, editing, and production with a variety of 3rd-party software. With KONA and a qualified computer, you have the ultimate system for production, post-production, broadcast, and streaming work. AJA software is distributed as a unified package which includes all the software, firmware, plugins, and utility programs for AJA's Io, KONA, and T-TAP products.

Retail packages are available for Mac, Windows, and for Ubuntu and Rocky Linux.

NOTE: Support for the Linux OS retail drivers is based on the Linux application used and comes from the application's vendor.

To download AJA software, go to the AJA website:

<https://www.aja.com/support>

For a complete software compatibility list, see the AJA website link:

<https://www.aja.com/compatibility/kona>

Mac, Windows and Linux Packages

These packages include:

Drivers

AJA device drivers for tightly integrated hardware/software operation.

AJA Control Panel

The Control Panel provides:

- Source selection and control of your AJA hardware
- A block diagram showing the signal routing and processing being performed

AJA Control Room

Control Room is a cross-platform software application for ingest, playback and output with AJA devices.

Additional with Mac and Windows Packages

AJA Plugins for Third Party Applications

AJA provides plugins for popular third party Professional Video Applications from Adobe, Avid, and Apple. This allows these applications to communicate with AJA hardware products and control their operation and parameters. These AJA plugins are automatically installed when you run the AJA Software Installer, for each and all of the third party applications previously installed on that computer.

NOTE: See <https://www.aja.com/compatibility/kona> for KONA IP25 and KONA family third party software compatibility.

Network Requirements

For IP installations specifically, AJA recommends the following:

- IP infrastructure with adequate bandwidth to sustain the capture and playback of the material you expect to be working with across the number of systems that are active at any given time.
- For multi-seat installations, IP infrastructure that is comprised of fully managed switches and is in turn supported by a team of qualified network administrators.
- For SMPTE ST 2022-7 implementations, two entirely independent network infrastructures are required for true redundancy.

A PTP clock source must be deployed and your switch must therefore be PTP aware. KONA IP25 utilizes 10GigE or 25GigE SFPs and must connect to switches that support the applied SFP bandwidth.

In all cases the switch used must be both managed (configurable) and IGMP aware.

SFPs are not included with the purchase of KONA IP25.

LLDP

LLDP (Link Layer Discovery Protocol) is supported with KONA IP25. The Chassis ID and the Port ID of the first switch encountered upstream in the path from KONA IP25 to the network will be displayed in Control Panel within the LLDP Chassis ID field and LLDP Port ID field. The first upstream switch, in turn, displays the LLDP information (Chassis ID and Port ID) of the downstream KONA IP25.

System Requirements

NOTE: On macOS, the KONA IP25 supports Apple silicon processors as well as earlier Intel processors.

NOTE: Installing the software requires adjustment to system security. See ["macOS Installations"](#) on page 16.

AJA Video recommends that your system meet minimum hardware and software requirements to achieve a satisfactory level of performance. Updates to system requirements are subject to change.

See the Release Notes for your AJA Card or Device, available on the AJA website and also installed with the software package, for minimum and recommended system requirements including OS, CPU, RAM, and GPU.

NOTE: See Software Vendor system requirements for GPU recommendations and additional hardware requirements and recommendations.

NOTE: For large scale installations with shared storage, IP, or for very high performance requirements, AJA recommends consultation with an experienced system integrator. A consultant will be able to assist with many important variables.

Disk Storage Methods

To ensure performance and quality, the disk storage system used with the workstation must be able to meet the demands of storing real-time uncompressed media. At the very minimum, the disk storage system must be able to provide and maintain a consistent transfer rate from the workstation to disk (read/write). There are a variety of system configurations and peripherals that can provide this level of performance.

For more on disk storage performance see ["AJA System Test Application"](#) on page 10.

KONA IP25 Connectors

SFP Cages and Modules

Two SFP28 cages are provided to connect two separate 10 GigE or 25GigE Ethernet Links. Both links are bi-directional.

IMPORTANT: Only fiber SFPs are supported. Copper SFPs and / or emSFPs draw too much power and may cause damage and / or operating instability.

Reference Clock

PTP (Precision Time Protocol) is required for KONA IP25 to function in a ST 2110 network.

Chapter 2 – Installation

Installation Overview

The installation and set up of a KONA card is simple, and may vary slightly depending on your system.

For the most up-to-date Windows and Mac system requirements for KONA, see the following on the AJA website:

<https://www.aja.com/page/system-configuration/>

Third Party Software Support

For further support information regarding third party software compatibility, see:

<https://www.aja.com/compatibility/kona>

AJA System Test Application

AJA System Test is a utility for measuring system performance with AJA KONA Video Capture cards. It is installed with the KONA Driver. The application includes:

- System Disk Test
- AJA Device Test
- Disk + Device Test
- System Report

The application tests Read and Write, Capture and Playback speeds tests in both Megabytes per second and Frames per second. The disk speed tests differ from standard disk I/O performance applications in that they specifically test the system under conditions typically encountered with video capture, playback, and editing.

NOTE: *One way to test storage performance is to fill the target disk to 80% and then test capture at the highest data rate you will use. This may not be practical in all use cases.*

KONA IP25 Card Access for Configuration and Control

The KONA IP25 card can be connected into various network environments via the 1GigE RJ45 port. These include:

- KONA IP25 to Host.
 - Network cable connection from KONA IP25 1GigE RJ45 port to host computer network port.
- KONA IP25 to isolated switch to Host.
 - Network cable connection from KONA IP25 1GigE RJ45 port to isolated switch then isolated switch to host computer network port.
- KONA IP25 to network infrastructure switch to other devices including Host.
 - Network cable connection from KONA IP25 1GigE RJ45 port to network infrastructure switch then potential connection to other devices including host computer network port.

NOTE: *By default, the KONA IP25 starts in DHCP mode (see "Network Tab" on page 51). If there is no DHCP server, the card can be accessed using a link-local IP address (ex. 169.254.x.x).*

NOTE: After connecting the network cable(s) and restarting the system, the External IP will be either a valid DHCP address or a 169.254.x.x link-local IP address. The External IP address for this card can be found in the Info screen of the Control Panel. See "Info Screen" on page 41. Clicking the IP Config button in the bottom left of the Control Panel (see "IP Config" on page 42) will open the WebUI at the specified address in the default system browser.

Tunnel IP Configuration (BETA)

KONA IP25 v17.6 includes a BETA option in Windows and Linux to access the KONA IP25 Web UI directly via PCI.

NOTE: Tunnel IP Beta only functions on Windows and Linux and is not supported for Mac.

Launch the **ajatund** application (called Tunnel) which provides access to the PCI from a Web browser:

Windows

1. On host PC :

- Go to C:\Program Files\AJA\Windows\Applications and right click on the **ajatund** application which provides access to the PCI from a Web browser.
- Choose 'Run as administrator'.

Figure 1. Tunnel Application

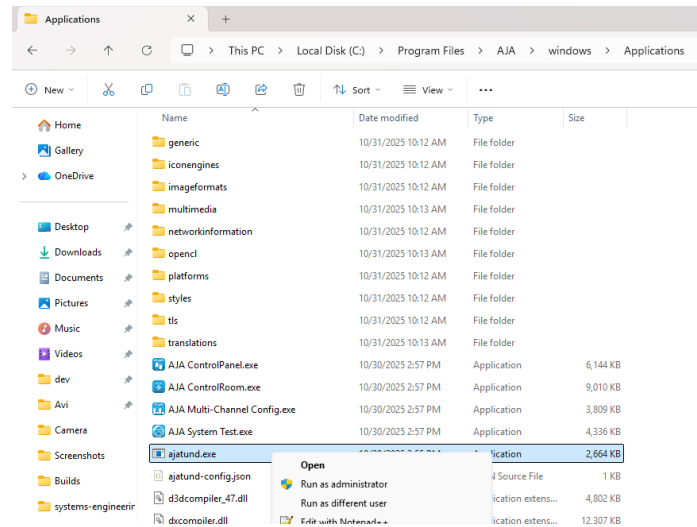

Linux

1. Linux via system services:

- To start the **ajatund** service, enter `sudo systemctl start aja-ajatund`
- To stop the **ajatund** service, enter `sudo systemctl stop aja-ajatund`

2. Linux via command line:

- To start the **ajatund** service, enter `sudo /opt/aja/bin/ajatund`

3. To stop the **ajatund** service, press CTRL + C from the terminal where the **ajatund** process was launched

Following launch of the application on either Linux or Windows operating systems, a Command Window will open and can be minimized but must remain open. If it is closed, the application will close.

NOTE: If RED errors are seen in the Command Window, it's likely the application was launched without administrative rights. In this case, please close the command window and relaunch the application with administrative rights.

Figure 2. Tunnel Command Window

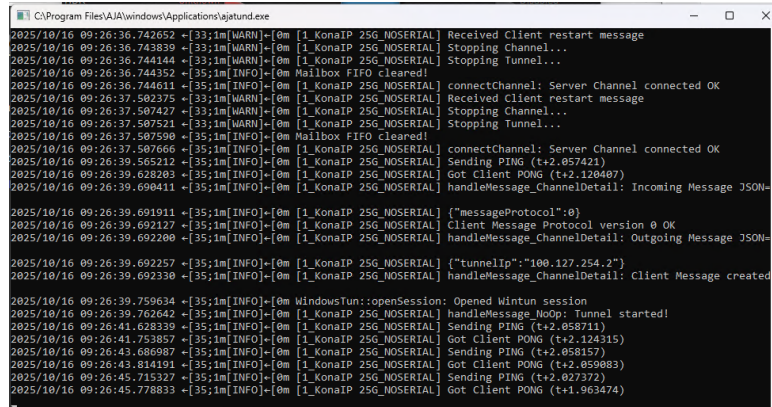

The application takes approx 1 minute to launch and will now be viewable in Task Manager. The Tunnel application needs to be launched each time the host pc is restarted.

Tunnel BETA in AJA Control Panel

1. In AJA Control Panel, select **Info** on the left. This will bring up the Info screen on the bottom of the Control Panel.

Figure 3. Info Screen with Tunnel IP Address

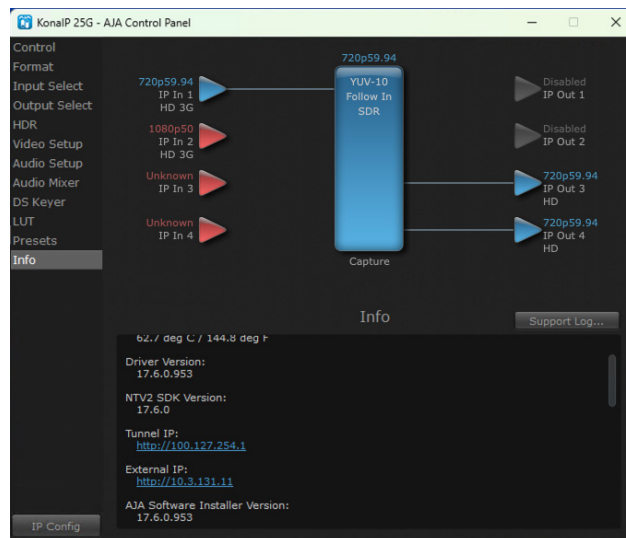

2. Inside the Info pane the **Tunnel IP** address will be visible. Select the Tunnel link and the Web browser will launch.

NOTE: External IP in the Info pane is for the RJ45 connection.

Unpacking

Shipping Box Contents

Your KONA shipment includes:

- KONA IP25 card

As you unpack your shipment, carefully examine the contents. Ensure you received everything and that nothing was damaged during shipping. If you find any damage, immediately notify the shipping service and supply them with a complete description of the damage. AJA will repair or replace damaged items. If you find shipping damage, contact your AJA dealer or distributor for details on how to have your KONA card repaired or replaced.

NOTE: Save packing materials and the shipping box. If you ever require service or move your system use the packaging materials and box for safe shipment.

Installing KONA Cards

Figure 4. KONA IP25 Card



The KONA IP25 card can be installed into a PC chassis, Mac Pro chassis with PCIe slots, or into a Thunderbolt 3 or 4 PCIe external chassis.

IMPORTANT: The KONA IP25 card has an option to use ATX power, if the host PCIe bus cannot provide sufficient power. For customers who wish to use a Thunderbolt 3 or 4 expansion chassis, the chassis must provide adequate power and if necessary ATX connectivity.

IMPORTANT: If a KONA IP25 is installed in an external chassis, make sure the power supply is sufficiently rated.

1. Uninstall previous version of AJA Desktop software (if any) for AJA KONA, AJA Io or AJA T-TAP from the host machine where your KONA IP25 card will be installed and connected. If prompted, restart the computer.
2. Shut Down the computer if it is on.
3. Turn off power to the host chassis.
4. Touch the outside of the chassis to discharge any body static.
5. Remove the AC power cable from the back of the chassis.
6. Open the chassis.

7. Locate a recommended PCIe slot (see ["Installation Overview" on page 10](#) for more information).

IMPORTANT: If a RAID controller is present, always put it and KONA IP25 card on separate PCIe buses. This improves performance by reducing bus contention.

8. Remove the blank backplate from the chosen PCIe slot, if one was there.
9. Touch the chassis to discharge any body static.
10. Remove the KONA IP25 card from its anti-static shipping bag.
11. Carefully insert the card by rocking it slowly into the slot. Ensure the card aligns properly with the slot opening and is fully seated.
12. Connect an ATX power cable from the host motherboard or chassis power supply (depending on the particular chassis) to the rear of the KONA IP25 card.

NOTE: Different PC hardware configurations can result in the text on the installed card bracket being upside down.

Figure 5. KONA IP25, ATX Power connection

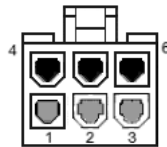
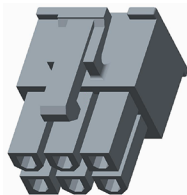
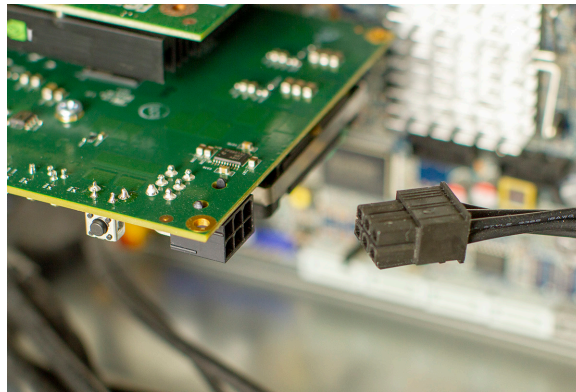

PC Internal ATX
Power Connector
1, 2, 3 = +12v
4, 5, 6 = COM
(Molex p/n 45559-0002)

13. Secure the card in the chassis such as by a backplates lock bar, or by using a screw through the backplate into the chassis.
14. Close the chassis.
15. Reconnect the AC Power cable to the chassis.
16. Power up the chassis.
17. Proceed to install the latest software.

NOTE: See ["Installing KONA IP25 Software" on page 16](#)

Cabling the System

KONA IP25 Cable Connections

10GigE or 25GigE infrastructure must be connected via optical fiber cable with appropriate SFPs.

Figure 6. IP Configuration Example for ST 2110 Workflow

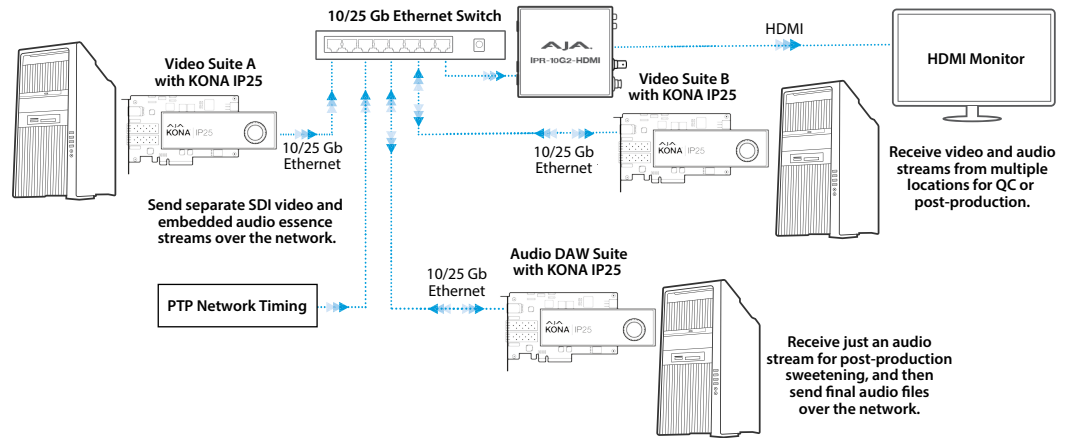

Figure 7. IP Configuration Example for ST 2022-7 Workflow

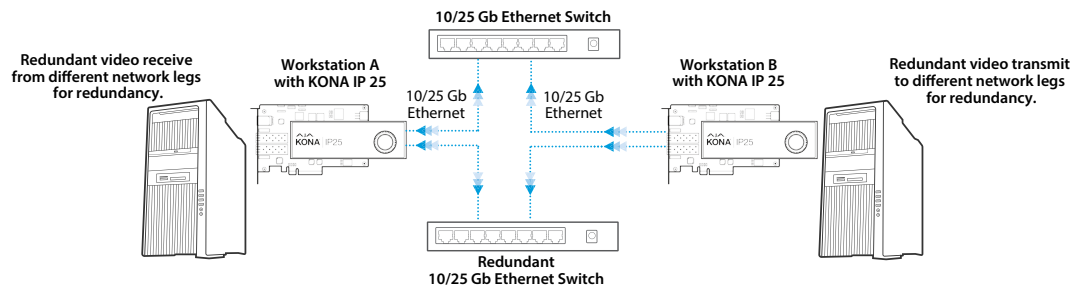
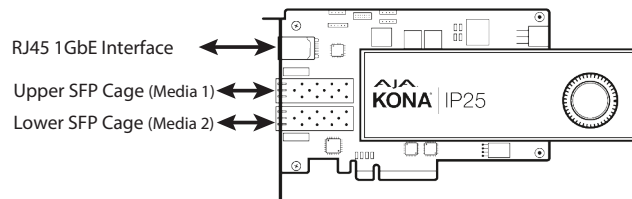

Figure 8. KONA IP25 Card Connections



The KONA IP25 card fits into a standard PCIe slot of a computer. The end spine has a 1GigE RJ45 connector for external configuration and control, and two SFP28 cages (Upper and Lower).

SFP Modules

Modules inserted into the two SFP28 cages can be used to connect two separate 10GigE or 25GigE Ethernet Links.

NOTE: The second SFP28 cage is used for ST2022-7 redundancy architecture only.

Inserting and Removing KONA IP25 Cards

SFP modules must be removed from the KONA IP25 card before the card can be inserted or removed from the host. Disconnect the LAN cables, if necessary, and then lift the lever to unlock the SFP modules for removal.

Installing KONA IP25 Software

NOTE: If the AJA SDK is installed, uninstall it before proceeding below.

Download

Go to the AJA website and download the latest AJA Software Installer package containing the AJA Control Panel and Control Room applications:

<https://www.aja.com/support/>

System software updates may occasionally become available to AJA KONA IP25 owners on our website. We recommend checking occasionally for both software updates and additional product information.

NOTE: If your computer has previously had another video capture or multimedia device installed, ensure you uninstall any related software before installing KONA IP25. This will prevent any hardware or software conflicts.

Software Package Installation and Re-installation

Before installing the KONA IP25 software package, ensure that your capture/editing application is installed as detailed in its user documentation. You cannot use KONA IP25 with a third-party application until the application has been installed and run at least once on your workstation. Next, install the AJA Software package.

If you add KONA IP25 supported applications at a later date and have not previously installed the appropriate drivers, you must run the install program again selecting the appropriate application support software to be installed.

macOS Installations

macOS versions from High Sierra (10.13) through macOS Sonoma (14.x) all have security requirements that may present dialogs during installation. Please refer to the Release Notes for guidance.

For MacOS Ventura (v13.x) and later, in order to install AJA Control Panel and Control Room on Apple computers, it may be necessary to enable KEXT (kernel extensions). During the installation process, you will be prompted to enable the AJA driver. If you do not see the option to enable this driver, it will be necessary to lower system security in the computer BIOS. To do this, complete the following steps:

1. Shut down the computer.
2. Depress and hold the power button on startup, for ARM (M1/2/3) processors. For Intel processor Macs, hold Command+T on startup.
3. When the BIOS setup appears, go to security utility and enable KEXT lower security.
4. Upon restart, the option to enable the AJA Software should then appear in the system security options.

KONA IP25 Firmware Installation

IMPORTANT: The firmware installed in your KONA IP25 should match the version of the AJA software package. If a mis-match is present, the KONA IP25 may not work and a "Not Valid, device needs firmware update" message will be displayed. Always update the firmware of your KONA IP25 when you install an AJA software package. In addition, a restart is required after changing firmware to enable NMOS registration.

Chapter 3 – Operation



Using KONA with Professional Video /Audio Software

After you install the AJA software package on your computer, you're ready to begin capturing and playing back video and audio using your choice of third-party software. You can go here for AJA software and documentation:

<https://www.aja.com/en/support/downloads>

For further support information and downloads for third-party software, go to:

<https://www.aja.com/en/category/edit/compatibility>

Capture Formats

When capturing, you can record data in the following file formats:

- BMP
- DPX
- MOV (QuickTime)
- MP4

NOTE: Support of QuickTime for Windows has been discontinued. However, ProRes family capture and playback for macOS, Windows and Linux is supported via AJA Control Room.

- MXF
- TGA

NOTE: Other file types can be captured using third-party capture applications.

AJA Control Panel Overview

The AJA Control Panel is a software application that provides a simple visual showing how the KONA IP25 hardware is currently configured and allows you to make changes. You can change signal input and output parameters and define the video processing that will be performed.

The AJA software installer automatically installs the Control Panel application on your computer.

AJA Control Panel Operating Modes

AJA Control Panel has two fundamental operating modes.

Playback Mode - Used for playing back video files from the computer, usually with a non-linear editing application (NLE) or AJA Control Room, through the KONA card to that card's video/audio outputs for viewing and/or external recording.

Capture Mode - Used for capturing video/audio signals that are coming into the KONA card from an external source to create video files on the computer using AJA Control Room or an NLE, or just for display on the KONA outputs. This mode is also used for stand-alone video display or conversion when Control Panel is being used without an external controlling application.

AJA Control Panel User Interface

The AJA Control Panel user interface includes a visual block diagram of the unit's current configuration. The current status, input and output settings, and many other details are depicted in the color-coded block diagram. Below this block diagram are various controls for changing operating parameters, which will vary depending on which function screen has been selected.

The left side of the AJA Control Panel provides a navigation list of available function screens. Clicking on a link (or alternatively, a related element in the block diagram) displays a function screen corresponding to that topic.

NOTE: Although KONA IP25 is sending and receiving video over IP, once that data is decoded to memory it is governed by the same video menus used for SDI and HDMI based AJA I/O solutions.

Figure 9. AJA Control Panel, Block Diagram and Controls

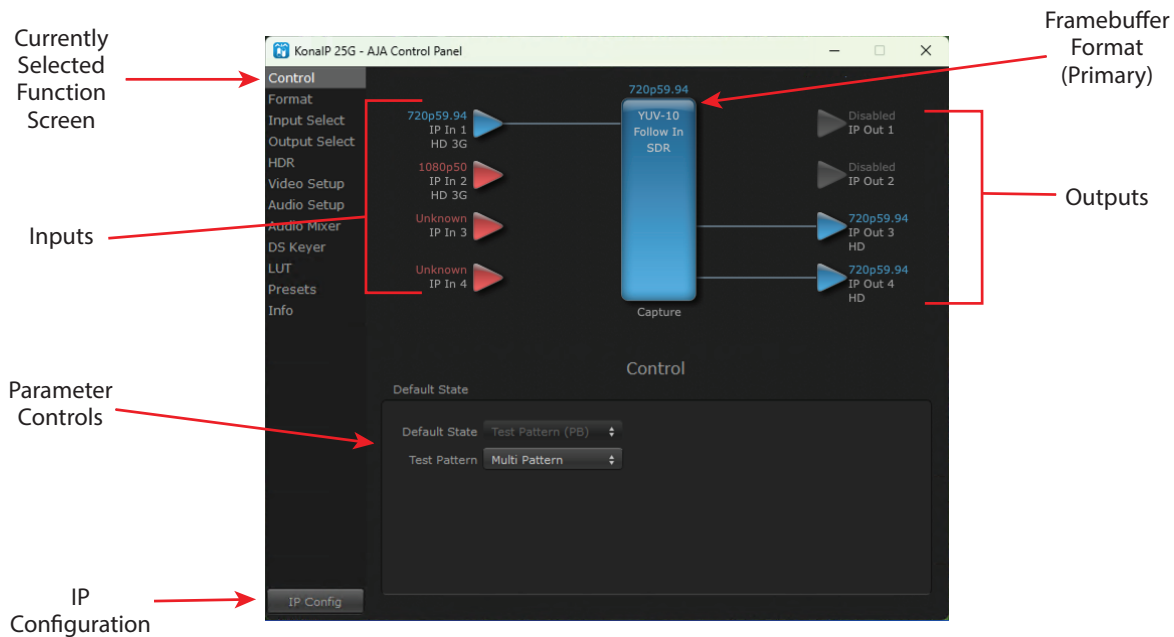

Block Diagram Area

The top block diagram area of the Control Panel screen is a visual representation of the processing, if any, that's currently occurring, including inputs/outputs, reference source, and system status. Lines between inputs, the framebuffer, and outputs, show a video path. Where there are no lines, there is no connection; this can be because an input or output isn't selected in the Input Select menu.

You can click any of the function screen selection links in the left column to view its current settings or click on an icon to call up its related settings screen. You can also right-click or Control-click to see context-sensitive information and choices.

Figure 10. Context Sensitive Menu

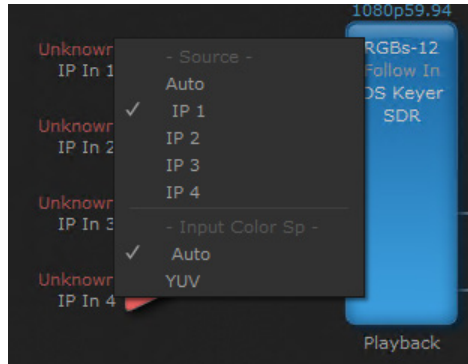

Color Meanings

All items in the AJA Control Panel block diagram are color-coded to show what is happening in real time. This applies to both icons and text. These colors indicate:

Blue

Video is same format as the Device Format (framebuffer).

Green

Indicates that KONA is performing an active change to the video making it different from the Device Format (e.g., down-conversion).

Red

The selected operation cannot be performed. This can be due to either a cable not connected, a signal not recognized, or a function not relevant to the current operating mode (capture vs. playback).

Yellow

Reference video (black burst or other reference source).

Input/Output Icons

The input and output icons are triangles that together with their color show all the input and outputs and their status (selected, not selected, input present or not, format, etc.). A complete video path is shown when inputs and outputs are connected with lines going to/from the framebuffer.

Figure 11. Input/Output icons



NOTE: *Hovering your cursor over an Input or Output icon opens a tooltip that reports that connector's signal status (Input signal detected, Output signal enabled, Input or Output disabled).*

Framebuffer

The framebuffer is the “engine” where your third-party applications interface with the AJA device. The framebuffer has a format (called the “Primary Format”) and color space that it follows, as defined in the linked menu screens or via external application software.

Device Format

The Device Format is the media format written to disk and used in your project. This is the format that the framebuffer will use and is shown in the Control Panel using the color blue. It is the format that the third-party application software will either receive from the AJA hardware, or is sending to the hardware. All icons in blue are the same as the Device Format used by the framebuffer. Also any text descriptions in the block diagram that appear in blue indicate that something is in the Device Format. For example:

- If the input and output icons are blue, you know that the same format is used throughout the video path. No format conversion is being performed.
- If the input or output icon colors differ (blue input and green output icons for example), you know that a format conversion is being performed.

Presets

Setups can be named and saved as a snapshot (Preset) for recall at any time. You can save various AJA device Control Panel configurations associated with your frequent tasks. You don't have to spend time resetting interface configurations, just load the previously saved Preset for each task. See ["Saving, Loading and Deleting Presets" on page 40](#) for more information.

If you work on multiple systems and want to carry your saved setups to another location, you can copy your saved Preset files on to movable storage and load them into any computer running the AJA Control Panel application.

Mac OS Preset Files Storage Location

- From the Finder, hold down the Option key (to display the Library directory) and click on Go/Library/Application Support/AJA/<device name>/Presets/

Windows Preset Files Storage Location

- c:\Users\<username>\AppData\Local\AJA\Control Panel\<device name>\Presets\

NOTE: When you visually browse to the above location, depending on Windows OS setting you may not be able to visually see the folder referred to in the path. Instead, you have to fill out the rest of the Windows path manually (i.e. type the rest of the address in the navigation bar when you hit the "end" of the browsing path).

Default Preferences

When an AJA device starts up, a preference can determine what settings it will have it when it begins to operate. The AJA Control Panel offers two default preference settings:

- Local Preference - A preference stored from the last AJA device's Control Panel settings to be used on next startup of AJA Control Panel. This occurs on next restoration of the default state (triggered by start up of host CPU, startup of the AJA device, or when a third-party application releases the AJA device).

- Global Preference - A preference saved for use as a global default start state for an AJA device that can be shared by multiple users, applied on first startup, or by pressing the Control Panel **Reset Device...** button.

Shared Preferences

An administrator can establish house standards for the AJA Control Panel by creating the user preferences file (described above) and placing it in a shared location where it will establish a standard default startup state for all users of a given computer system. These settings preempt the initial AJA default settings.

To establish the House Default for every user on every system, a system or network administrator can move this default file to all systems on the network (manually or by pushing it out across the network). All users on the network will then open to the House Defaults when they launch the AJA control panel for the first time.

NOTE: If the user makes changes to the control panel themselves, those changes will be saved in their user preferences, which will take priority over the house default dictated by the shared preferences file.

The Shared Preferences file should be a file created at the User Preferences location described above, and placed by the System Administrator in the following locations.

On Mac:

/Users/Shared/Library/Preferences/com.aja.devicesettings

On Windows:

C:\Users\All Users\Aja\com.aja.devicesettings

Global Preference

An administrator can establish a house standard for an AJA device by copying a preference file to a shared computer location. Once placed at that location, it becomes a Global Preference file where it will establish a standard default startup state for all users of that AJA device using that computer system. These settings preempt the initial AJA factory default settings, and are applied when an AJA device is first powered up, or when the Control Panel **Reset Device** button is pressed.

To establish a Global Preference, the administrator first configures the AJA device (which automatically creates a "com.aja.devicesettings" Local Preference file in the location identified above) and then copy or move that file to the correct computer locations (manually or by pushing it out across the network) on all the computers that use the AJA device.

NOTE: If the user makes changes to an AJA Device's Control Panel settings, those changes are saved to the Local Preference file, which will take priority over the Global Preference file.

The shared computer locations for a Global Preference file are:

On Mac:

- From the Finder, click on Go/Computer/<System HD>/Users/Shared/AJA/ and copy or move the "com.aja.devicesettings file" described above to this location.

NOTE: The "AJA" folder needs to be created manually at this location before moving the preference file into it.

On Windows there are three possible shared locations depending on your system:

- C:\Users\Public\Aja\
- C:\Users\All Users\Aja\
- C:\ProgramData\Aja\

Copy or move the "com.aja.devicesettings file" described above to one of these locations.

NOTE: The AJA Control Panel Info screen displays the path to the Global Preference file on that computer.

NOTE: Clicking on the AJA Control Panel Erase All Prefs button does NOT delete an existing Global Preference file from this location.

Controlling Application

It is important to understand that the computer can contain many applications that can use the AJA device (as you switch from window to window) and it may not always be obvious which currently controls it.

Figure 12. Control Panel In Use Message

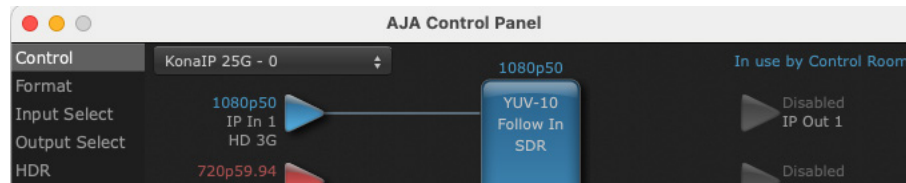

In the top right corner, the Control Panel displays the name of the application controlling the unit. In some cases, applications may not always properly “let go” of the I/O interface as another takes over—you’ll be able to tell by looking at the Control Panel.

Using Multiple AJA Products

More than one AJA product can be installed and available to your host computer. Using the AJA Control Panel application, you can choose which installed product an application uses for input/output. In the upper left corner of the AJA Control Panel application, you will see a board name, such as KONA IP25 and the pane heading will read “AJA Control Panel” if you have more than one product and the associated drivers installed (if only one product is installed, you’ll see no product or pulldown and the product name will appear in the header). To “target” a specific installed product for use, click on the text in the upper left hand side of the UI and select from the list of available products that appear in the pulldown.

Figure 13. Control Panel Screen showing multiple AJA devices

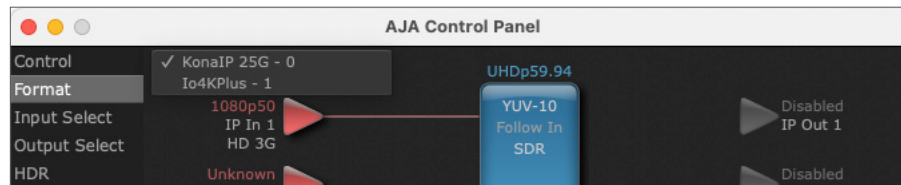

When you launch an editing application, or AJA Control Room, the application will use the product that is currently selected in the AJA Control Panel for its input/output. When an application is running, you can change the “targeted” product selection using the Control Panel pulldown menu. The running application will retain its connection to the product. If you change the “targeted” product and launch a different application, that application will use the new product for its input/output, while the first application you launched will continue to use the other AJA product.

Notes on Using Multiple AJA Products:

Performance of multi-product use depends on a variety of factors: CPU usage, RAM, disk IOPS/ bandwidth for streams of video, etc. and therefore performance may vary. Also be aware that multiple input/output streams are only supported by software that is explicitly designed for a multi-product environment.

Function Screens

Listed below are the function screens for KONA IP25 and what they are used for.

Table 1. KONA IP25 Function Screens

Screen	Functions
Control	Configure some basic KONA IP25 operation options and output timing.
Format	Select the framebuffer Device format.
Input Select	View and edit input selections and audio mapping.
Output Select	Select output format.
HDR	Configure High Dynamic Range settings output
Video Setup	Configure Video such as composite black level, progressive format and ancillary data (Closed Caption) option.
Audio Setup	Configures Audio options.
Audio Mixer	Select and mix audio sources for playback and capture.
DS Keyer	Setup and control the insertion of keyed video from the frame buffer or graphics files with alpha channel.
LUT	Load a lookup table (LUT) file to adjust the calibration of color for any source.
Presets	Add or delete saved preset configurations (handy for quick and easy recall of different KONA IP25 settings for varied workflows).
Info	Display status information and the firmware version number. This information is generally intended for troubleshooting/support.
IP Config	Allows IP configuration including Inputs, Outputs, Network settings, Global Controls, Precision Time Protocol (PTP), and Firmware.

Control Panel Operation

Control Screen

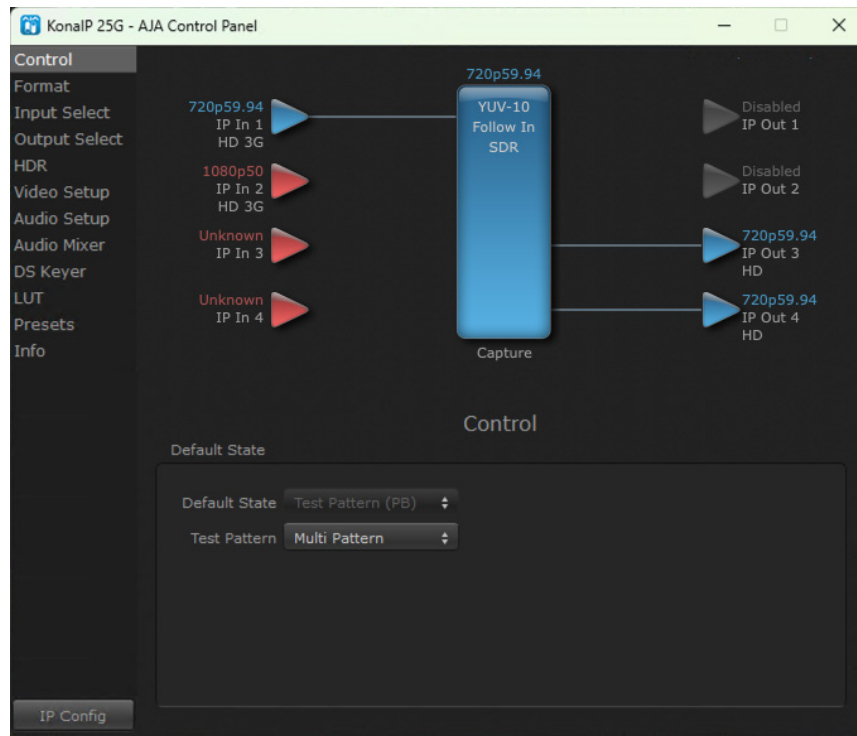

The KONA IP25 card can be controlled by various software applications running on a host computer. The Control screen is where you select how the KONA IP25 directs video and is used by application software. The top of the Control Screen shows the currently selected AJA device if more than one is available in your system.

Default State

Many video applications can grab control of the KONA IP25, so its outputs can change dynamically. The Default State settings are used to select what state the KONA IP25 will have when no third-party video application is controlling it.

- Pass Through (Cap) - This selection directs KONA IP25 to route video from its selected input through the card for processing and output.
- Test Pattern (PB) - This selection directs KONA IP25 to output a preset pattern when no other application is in control. The pattern is selected from the Test Pattern dropdown list below, or a graphic file can be chosen.
- Hold Last App - This selection directs KONA IP25 to hold and output the last frame of video from the last application to control KONA IP25. This can be helpful when operating in an environment where you're switching back and forth between multiple application windows.

Test Pattern

With Test Pattern selected above, you can choose the pattern type. Select from:

- Black, Color bars (75% or 100%), Ramp, Multiburst, Line Sweep, Multi Pattern, Flat Field, Check Field, White, Border, Linear Ramp, Slant Ramp, Zone Plate, Color Quadrant, Color Quad Border, or 2SI Alignment (see below).
- 2SI Alignment - This test pattern consists of one-pixel diagonal crosshairs plus a three-pixel rectangle. If there is a misalignment, the diagonal crosshairs will not be a continuous line. If it is a top-bottom misalignment, the top and bottom of the square line will be broken, with white between them. If it is a left-right misalignment, the left and right lines of the square will be fuzzy or broken. This can easily be simulated by clicking the "Quad Swap" buttons in the control panel "Video Setup" tab.

For HD and UltraHD with RGB-12 Pixel Formats the following HDR test patterns are available:

- HDR Zone Plate, HDR Linear Ramp, HDR HLG Narrow, HDR PQ Narrow, or HDR PQ Wide.

Format Screen

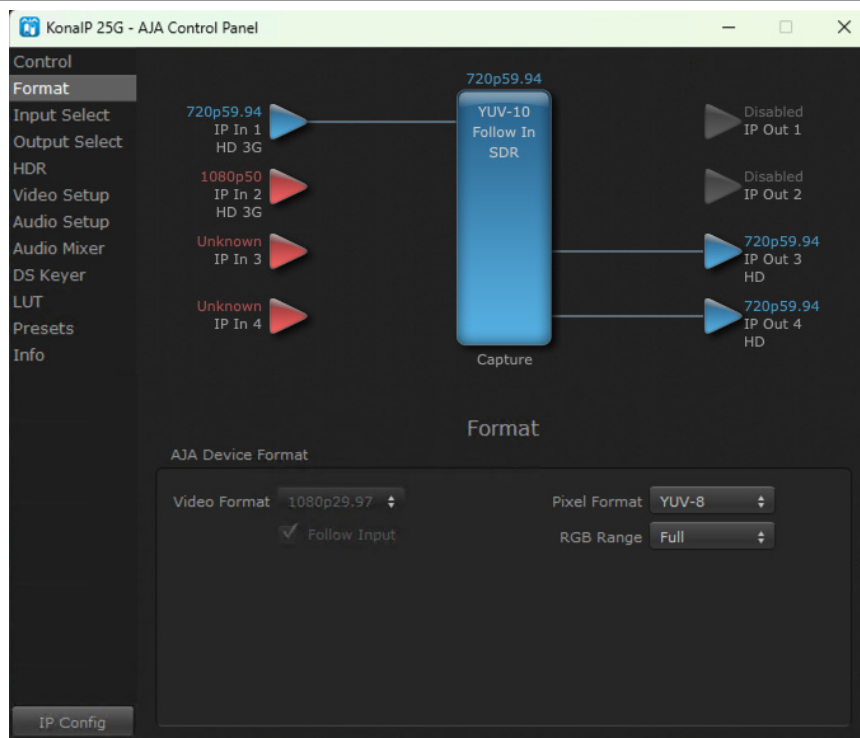

The Format Screen shows the video format currently in use by the KONA IP25 framebuffer (called the Primary Format) and allows you to change it. All throughout the Control Panel, choices are always presented based on what KONA IP25 can do with the signals available and the inputs/outputs selected.

AJA Device Format

Video Format

This pull-down menu shows the currently selected Device format, within a list of all available video formats. If you select an alternate format using the pull-down, it will change the format used by the KONA IP25 framebuffer.

When a change is made via the Video Format pull-down or by clicking an icon and selecting a new format via a contextual menu, the block diagram will change to reflect the new format.

Follow Input

Enabling the Follow Input checkbox allows the Control Panel Buffer to auto-switch to whatever is the detected input format. This feature works only if the controlling application supports input-based capture—AJA Control Room for example.

NOTE: *The Follow Input setting must be set correctly for proper operation. See "Format Screen" on page 25*

Pixel Format

Use this pulldown menu to choose: Auto, YUV-8, YUV-10, ARGB-8, RGB-10 or RGB-12.

NOTE: *RGB workflows will colorspace convert to YUV on output automatically, except if RGB-12 is used, in which case Output colorspace must be set to YUV.*

RGB Range

The RGB Range pulldown menu allows you to select either Full-range (0-1023) or SMPTE range (typically 64-940) for RGB color output.

Input Select Screen

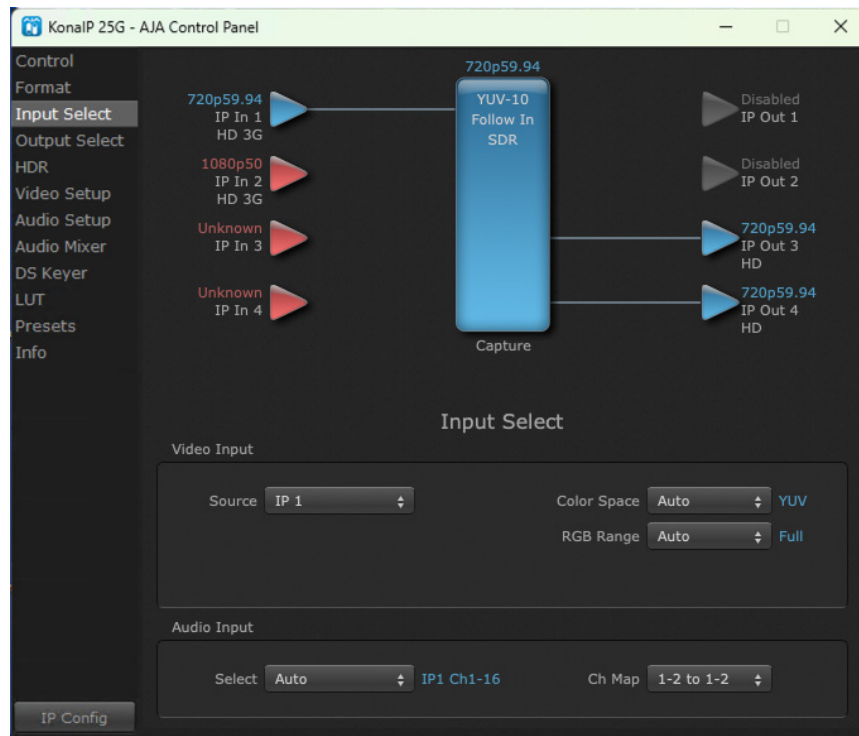

On the Input Select Screen, you can view the currently selected video and audio input sources and map audio sources to the channels supported by your editing application. Two information panes in the screen are provided: Video Input and Audio Input.

Video Input

Source

Select the Video Input source. Choose from IP 1 or IP 2.

Color Space

Sets the input color space. Select from:

- Auto - Automatically selects the color space depending on input format.
- YUV - Forces a YUV input color space.
- RGB - Forces a RGB input color space.

RGB Range

The RGB Range pulldown menu allows you to select from Auto, SMPTE, or Full.

Audio Input

Select

Up to 16 embedded audio channels (if present) are selected for input.

Ch Map

If only two channels were selected in the third-party application you are using, you can select which two channels will be mapped to that application. Different Audio Input selections can have different channel mapping capabilities. Select from:

- 1-2 to 1-2
- 3-4 to 1-2
- 5-6 to 1-2
- 7-8 to 1-2
- 9-10 to 1-2
- 11-12 to 1-2
- 13-14 to 1-2
- 15-16 to 1-2

NOTE: *This setting does not affect the audio being sent to the KONA IP25's output connectors.*

Output Select Screen

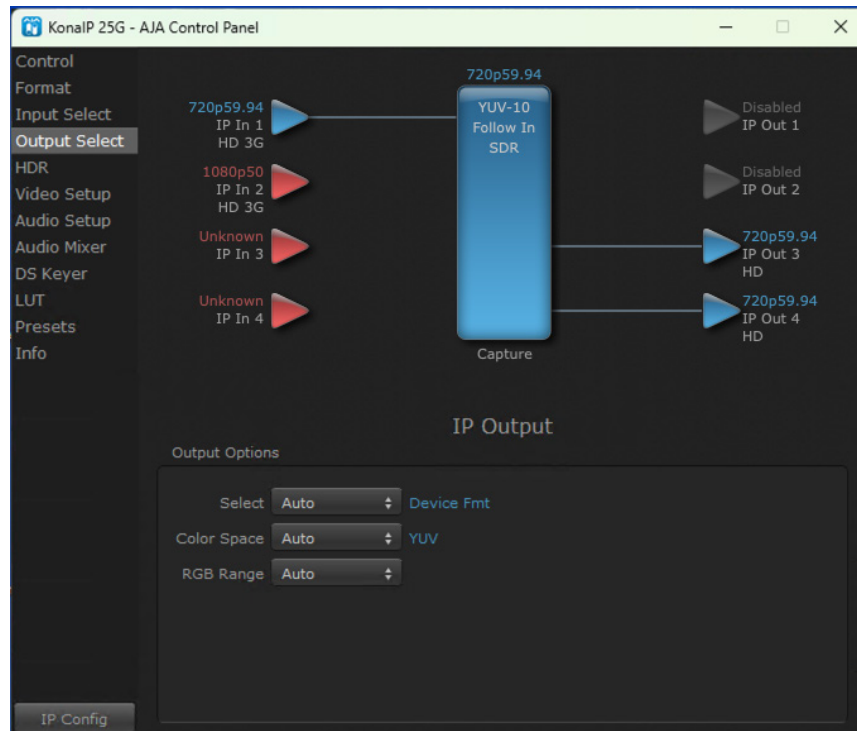

The Output Select Screen shows the current settings. Both IP outputs carry the same signal.

Output Options

Select

- Auto - Automatically selects the output format, based on the input or selected format.
- Device Format - Selects the framebuffer format for output.
- Video+Key - When selected, this indicates that the IP Video 3 is set to the same format as the framebuffer. IP Video 4 is set to a video key signal associated with IP Video 3 (the shape to be cut out from the video - this will appear as a black and white image/matte). Using the second KONA output as an Alpha Channel key, with the video output, may be useful for feeding production switchers, DVEs or other professional video equipment.

Color Space

Sets the color space. Select from Auto, YUV, or RGB.

RGB Range

The RGB Range pulldown menu allows you to select from Auto, SMPTE, or Full.

HDR Screen

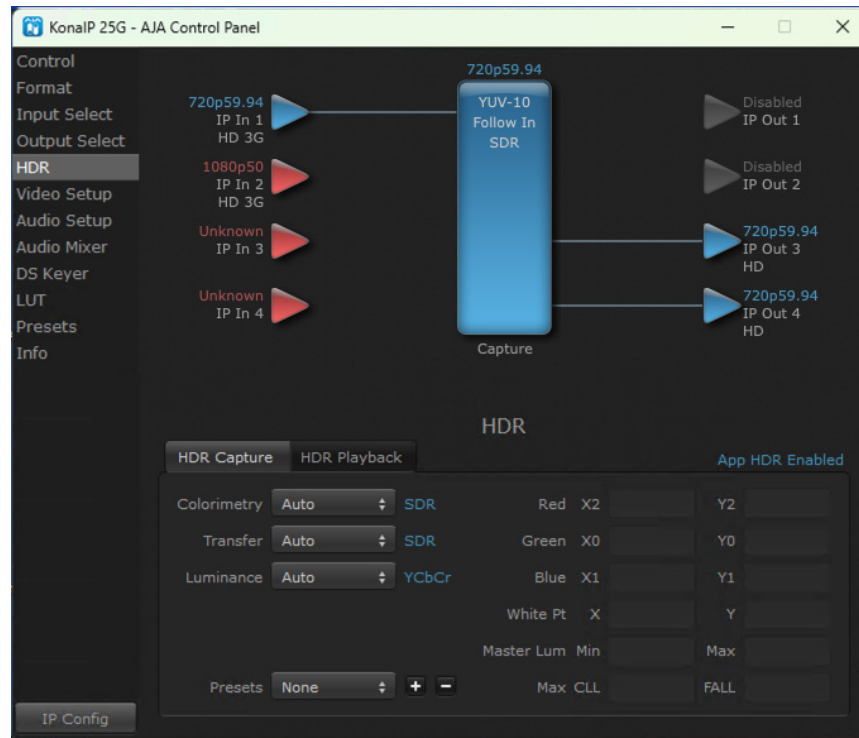

The HDR screen provides sub tabs for configuration of HDR Capture and HDR Playback. Two tabbed screens are available. The HDR Capture tab settings affect the HDR metadata saved with your captured video, while the HDR Playback tab settings affect what HDR metadata is included in the KONA IP25's SDP.

HDR Capture

Colorimetry

- Auto - (default)
- SDR - Standard Dynamic Range
- 2020 - BT.2020, typically used with HDR
- Custom - Allows specification of custom values

Transfer

The Electrical Optical Transfer Function metadata bit tells the display which EOTF to use.

- Auto - (default)
- SDR - Standard Dynamic Range
- PQ -
- HLG (Hybrid Log Gamma) - No meta-data for Digital Primaries

Luminance

- Auto - (default)
- YCbCr
- ICtCp

Presets

Allows user to save preset configurations and recall saved presets.

HDR Playback Settings

The HDR Playback tab settings are identical to the HDR Capture settings and are inserted into the SDP file.

Video Setup Screen

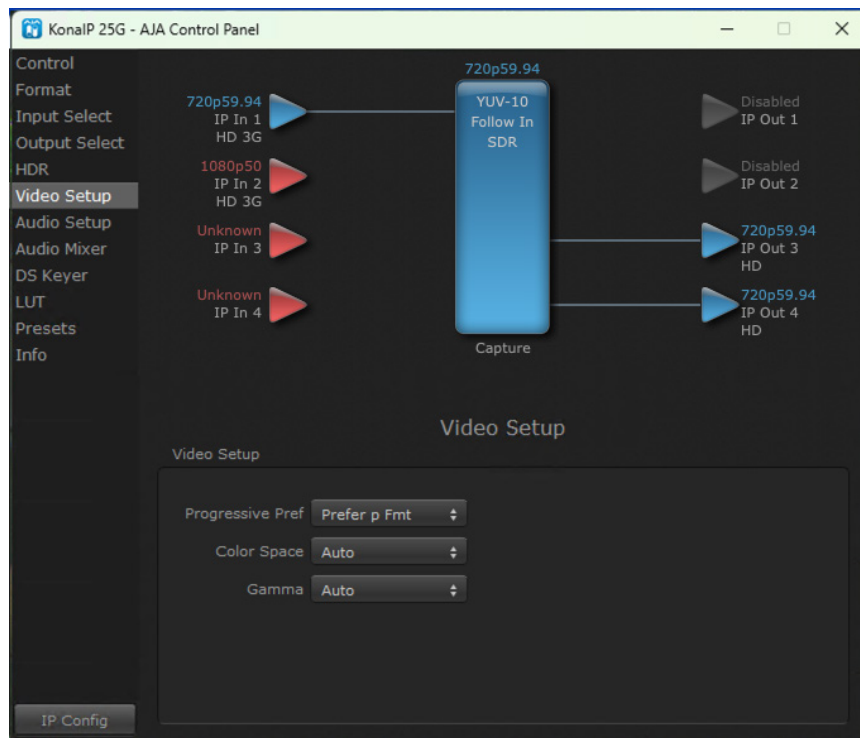

The Video Setup screen shows various other settings which will affect how video inputs and outputs behave, and how KONA IP25 interacts with some software applications.

Video Setup

Progressive Pref

This feature is used to default the hardware to use either p (progressive frames) or PsF (progressive segmented frames) output when it has not been specified by the application.

NOTE: Selection is included in Control Panel but has no use case for ST2110.

Color Space

Sets the video color space. Select from:

- Auto
- Rec 601
- Rec 709

Gamma

Sets the video gamma. Intended for use with legacy Apple displays. Select from:

- Auto
- Gamma 1.8

Audio Setup Screen

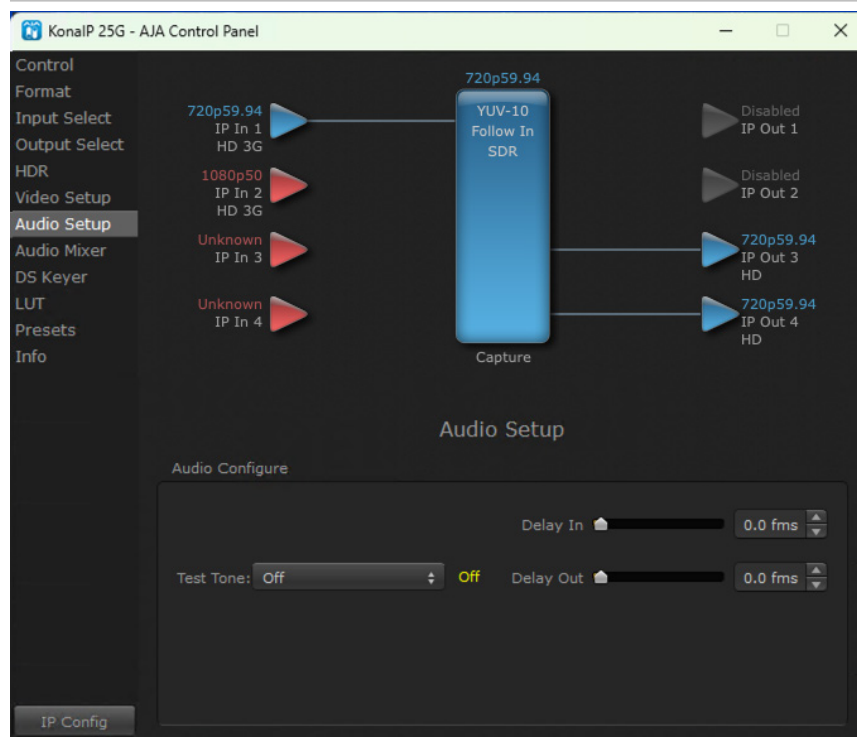

The Audio Setup Screen shows the current settings for the audio output, allowing you to re-configure it when desired.

Audio Configure

Test Tone

When enabled, allows generation of test tone. Three choices are available:

- Off - No test tone generated.
- Uniform -20db 400Hz - Uniform test tone generated for all channels.
- Non-Uniform - Generates test tone with unique level/frequency for each channel 1-16. See "[Non-Uniform Test Tone](#)" on page 31.

Table 2. Non-Uniform Test Tone

Channel #	Level	Frequency
1	-26.0dB	62.5Hz
2	-22.3dB	125Hz
3	-20.0dB	250Hz
4	-18.0dB	500Hz
5	-16.3dB	1000Hz
6	-15.0dB	2000Hz
7	-13.9dB	4000Hz

8	-14.0dB	8000Hz
9	-14.0dB	8000Hz
10	-13.9dB	4000Hz
11	-15.0dB	2000Hz
12	-16.3dB	1000Hz
13	-18.0dB	500Hz
14	-20.0dB	250Hz
15	-22.3dB	125Hz
16	-26.0dB	62.5Hz

Delay In / Delay Out

Allows you to configure up to 6 frames (in tenths of a frame) of delay for KONA IP25 audio input and output.

IMPORTANT: If you use this Control Panel delay, do not use other delay settings in your applications. Doing so may cause conflicts.

Audio Mixer Screens

The Audio Mixer screen has two tabs; Playback and Capture. These tabs display what sources are available for monitoring / mixing via the AJA hardware when in either of those two modes (if applicable). The controls on this screen are dedicated only to monitoring adjustments, and do not affect the level at which inbound audio signals are captured to storage.

IMPORTANT: Even though you can hear changes in the signals and levels adjusted with the Audio Mixer screen, these changes are NOT recorded to disk during NLE Capture or Audio Punch In / Voice Over to Timeline. In addition, muting or activating sources on this screen will not affect audio signals being recorded. The Audio Mixer screen is dedicated for monitoring only, not program mixing.

The branching arrow on the lower right indicates which sources are being routed for monitoring in that operating mode, and is colored blue when active and red when disabled.

Each source has a confidence meter, which enables you to tell immediately if you have a source arriving correctly at the AJA hardware (without having to launch any other software). The level sliders allow a simple plus or minus adjustment to the Source level being monitored. This is to allow for fine-tuning of your listening environment (on occasions the host system audio can be unexpectedly loud, or an incoming feed may be very loud or very quiet).

Two different Audio Mixer screens are available, selected by clicking on the Playback Monitor or Capture Monitor tabs. During regular editing, the Playback tab is used to control your monitoring experience. During capture operations, the Capture tab is used for your monitoring experience.

Controls in each tab are only in effect when KONA IP25 is in the correct operating mode, as determined by the controlling application or the Control Panel application's Default Output setting. When the mode doesn't match, the mode indicator on the right goes red. However, settings can be adjusted while in that disabled mode, and will be applied when you return to that operating mode.

Audio Mixer Capture Monitor Tab

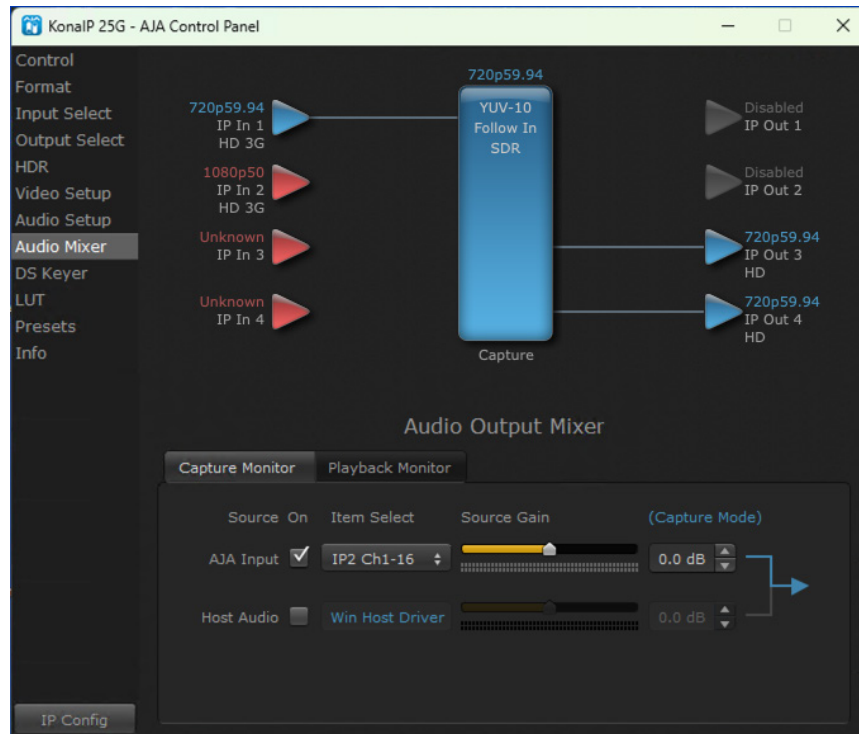

The Capture Monitor Mode screen is used to select and mix audio to be monitored during capture operations.

IMPORTANT: Even though you can hear changes in the signals and levels adjusted with the Audio Mixer screen, these changes are NOT recorded to disk during NLE Capture or Audio Punch In / Voice Over to Timeline. In addition, muting or activating sources on this screen will not affect audio signals being recorded. The Audio Mixer screen is dedicated for monitoring only, not program mixing.

The controls on this screen are similar to those on the Playback Monitor Mode screen, except the Main App is not available for selection (you cannot capture from the application that is capturing). See ["Audio Mixer Playback Monitor Tab" on page 34](#) for more information.

NOTE: If you want different behavior when the Capture tab is triggered; i.e. for host system audio to be muted, then simply check the host system audio in the Capture tab only. This way when you exit NLE Capture and return to regular editing, the Playback tab settings will be applied and your host system audio monitoring will resume.

These controls are for monitoring only, and do not change the audio recorded to a NLE file. Any actual recording level adjustments to Capture or Audio Punch In / Voice Over to Timeline operations will either need to be made upstream of the AJA input, or else via adjustments within the main NLE application (e.g. via a pass through mix tool).

Audio Mixer Playback Monitor Tab

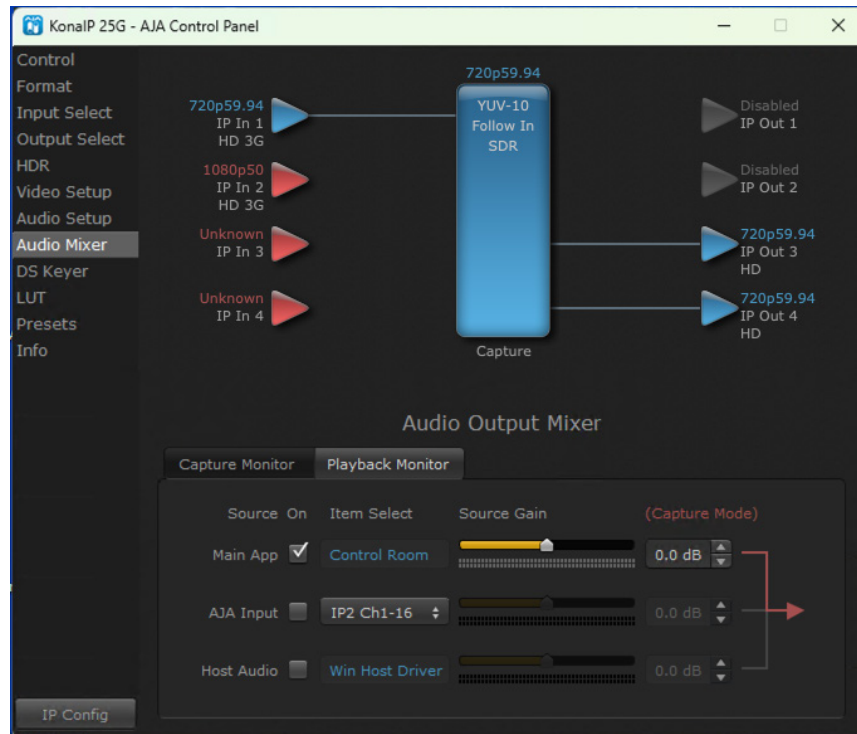

Playback Source Selection

Clicking the On checkbox selects the audio for that item for playback to the audio monitor outputs. Multiple sources can be selected simultaneously.

Main App

If an external application is controlling the KONA IP25, it will be displayed in the Item Select column and its audio can be selected for playback with the checkbox.

AJA Input

Selects the audio being input the KONA IP25. In the Item Select column, click on the AJA Input dropdown menu and choose from:

- Auto - Automatically selects audio as detected.
- IP1-4 (Audio from ST 2110-30) Ch 1-16
 - Up to 16 audio channels from specified IP via discrete audio essence within the ST 2110 payload are selected for input monitoring.

Host Audio

Selects the audio from the host computer, thus enabling the AJA hardware to monitor anything that would normally be presented via the host laptop, CPU or computer monitor. For example, an editor could sample music from an online library, while concurrently playing back their NLE timeline. Or, a producer and editor could be communicating live during an editing session, using Skype or some other video calling tool.

Source Gain

Meters display the input audio levels of the source, colored green when that source is On, and gray when that source is not selected. The levels shown do not change when the gain is adjusted, because the input levels are being monitored, not the output levels.

When activated, the source gain controls can be used to adjust the monitoring output gain of that source, from +6dB to - infinity (mute). Adjustment methods include:

- Sliders - The sliders on the right can be used to change the values for each color.
- Numeric Entry - You can enter a numeric value by clicking on the displayed number, and can then increase or decrease the values by clicking on the up/down arrow boxes.
- Cut and Paste - Right clicking on a displayed number opens a Cut, Copy, Paste dropdown menu for convenient numeric entry.

DS Keyer Tab

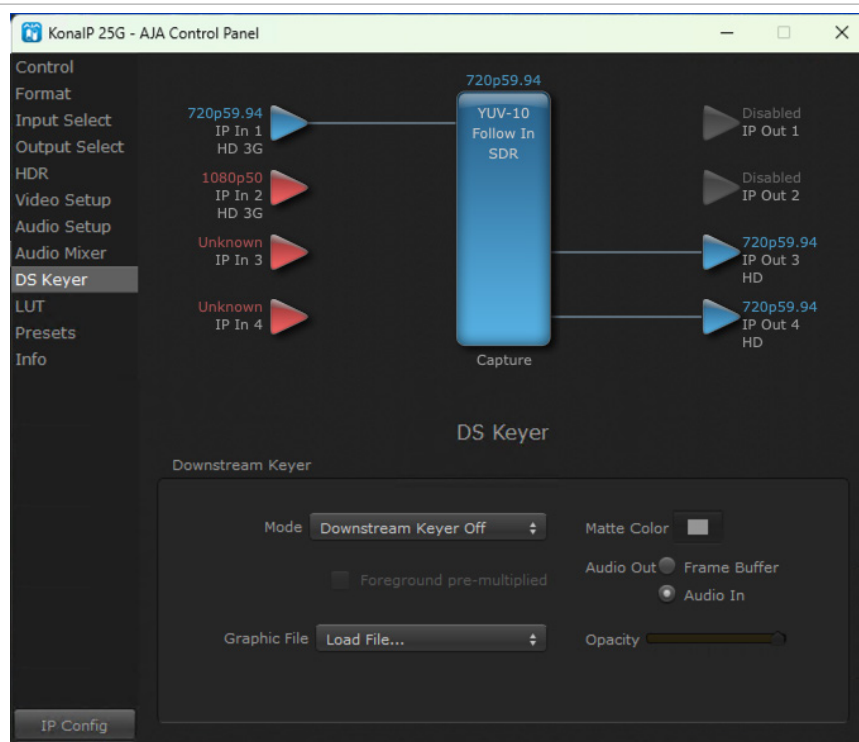

The KONA IP25 has a hardware-based Downstream (DS) Keyer which is used to create a Video + KEY signal for playback. A typical application is to put a television station's call letters or channel over program video content. Keyed video from the KONA IP25 is created from a graphics file that has an alpha channel (Photoshop etc.)

The DS Keyer has two modes to select from and is accessed through the web browser interface in the System tab. See "[System Tab](#)" on page 55.

- 4:2:2 10bit YCbCr (default): Video + KEY mode. This mode color converts through CSC into two streams, one 4:2:2 Video, and one 4:2:2 KEY. This mode does not signal as a KEY in SDP.
- 4:0:0 10Bit (KEY in SDP): This mode color converts through CSC into two streams, one 4:2:2 Video, and one 4:0:0 KEY. This mode does signal in SDP and does not deliver the Chroma component in KEY.

NOTE: Some receiving products do not accept 4:0:0. Verify that receiving products accept 4:0:0 before selecting this mode.

Downstream Keyer Mode

Downstream Keyer Off

When this pulldown menu item is selected the downstream keyer will be turned off.

Frame Buffer over Matte

Places the keyed video with alpha channel currently in the Frame Buffer over a fixed color matte determined by the "Matte Color" setting set separately.

Frame Buffer over Video In

Places the keyed video currently in the Frame Buffer over the video input for playout or print-to-tape.

Graphic over Matte

Places a graphics file having an alpha channel (chosen in "Graphic File" pulldown) over a fixed color matte determined by the "Matte Color" setting set separately.

Graphic over Video In

Places a graphics file having an alpha channel (chosen in "Graphic File" pulldown) over the video input for playout or print-to-tape.

Graphic over Frame Buffer

Places a graphics file having an alpha channel (chosen in "Graphic File" pulldown) over the current contents of the KONA IP25's Frame Buffer (which might be from storage, video In, KONA TV, etc.).

Matte Color

Only available when the pulldown "Frame Buffer over Matte" or "Graphic over Matte" are selected—pressing this button brings up a color selection dialog. The dialog provides a variety of ways to select a matte color including a color wheel, color picker (choose from a location anywhere on the computer screen), numeric sliders, swatches, "crayons", and spectrums. The matte chosen will be used as a video background under the keyed video.

Foreground pre-multiplied (checkbox)

Use to avoid "matte lines" and improve the appearance of the foreground (key) being composited over the background.

Audio Out

Frame Buffer

Select audio out to be routed from the contents of the Frame Buffer.

Audio In

Select audio out to be routed from KONA IP25's currently selected input(s).

Opacity

This slider controls the transparency of the keyed video (over the background) from translucent to completely opaque.

Graphics File

This pulldown allows you to choose from any recently accessed file or select a new file ("Load File..."), which then brings up a file dialogue. Remember that the file raster (pixel x pixel count) should match the primary format in the frame buffer. Example: you wish to key a logo on top of your 1920x1080 footage, the still image with alpha channel that you load should be 1920x1080.

LUT Screen

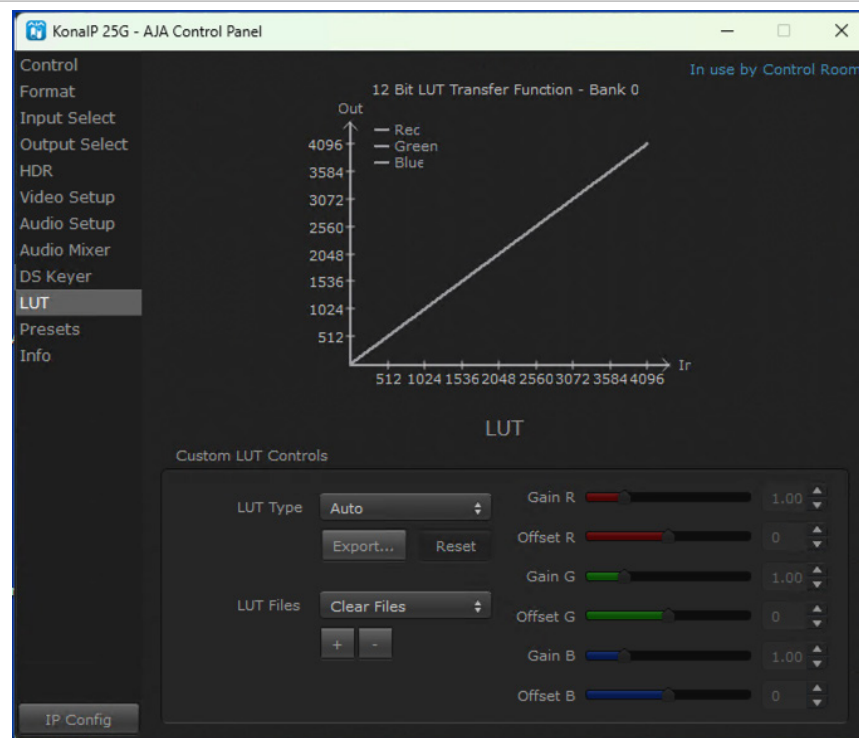

The LUT screen allows you to create a custom color look up table (LUT) on the KONA IP25 output, for matching a production "look" on a specific display. These custom LUTs can also be exported as .cube files for use with supported AJA devices and compatible professional applications. Users can also load externally generated LUT files into the KONA IP25 to ensure consistent color among different devices.

NOTE: .cube files are the new standard for importing and exporting LUTs with AJA Control Room as of v16.2. Prior to v16.2, Control Room supported CSV files containing LUT information. While this LUT formatting is still supported for import, it is no longer supported for export.

Custom LUT Controls

The LUT Transfer Function screen displays an approximate representation of the effect of the current LUT settings. When the controls are activated by selecting a User LUT Type, Red, Blue, and Green curves show the transfer functions of each color.

NOTE: The displayed curves are approximate. Curves for some extreme settings may diverge significantly from the actual transfer functions.

LUT Type

Selects the type of LUT. Choose from

- Auto - LUT will be automatically selected. This setting intelligently applies the type of LUT required in the majority of use cases.
- Linear - A linear 1:1 LUT is applied, resulting in no color change (every value for source is mapped to the same value for output).
- SMPTE->FullRange - A conversion LUT from SMPTE to Full Range is applied.
- FullRange->SMPTE - A conversion LUT from Full Range to SMPTE is applied.
- User Linear - Activates the Gain and Offset controls, allowing the manual creation of a custom LUT. Initial default setting is linear.
- User Log - Activates the Gain and Offset controls, allowing the manual creation of a custom Log LUT.

Figure 14. Example LUT Transfer Function Curves



- User LUT File - See "[LUT Files](#)" below.

Gain and Offset Controls

When activated, the controls on the right allow adjustment of Gain and Offset for Red, Blue and Green.

- Sliders - The sliders on the right can be used to change the values for each color.
- Numeric Entry - You also enter a numeric value by clicking on the displayed number, and can increase or decrease the values clicking on the up/down arrow boxes.
- Cut and Paste - Right clicking on a displayed number opens a Cut, Copy, Paste dropdown menu for convenient numeric entry.

Export

The Export button can be used to save the current LUT values as a .cube file. The LUT file can be named and you can specify the location to save the file. This Export feature lets you take the custom LUT with you and re-import it to another system or location for consistency.

Reset

Clicking on the Reset button resets the currently selected LUT Type to its default values (not active for a User LUT file).

LUT Files

The User LUT File setting above activates the LUT Files dropdown, allowing the selection of a previously saved LUT file. You can create a custom LUT file using most text editors or spread sheets, provided the data is arranged according to the LUT File Format Specification that follows (see ["LUT File Format Specification" on page 39](#)).

Uploading Custom User LUT file

Once the LUT file is created, you can upload it with the following steps:

1. Before loading a LUT, make sure you are using an RGB/RGBA frame buffer format, and that you have a AJA Video Device that supports LUTs.
2. Open AJA Control Panel and select the "LUT" pane.
3. Click the "LUT Type" popup and choose "User LUT File" menu item. Note "LUT Files" options become enabled.
4. Click the "+" button and use the navigation dialog to choose a custom LUT file. The LUT is now loaded.

LUT File Format Specification

LUT files are normal text files that contain 1025 lines (numbered 0 - 1024). Each line contains 3 integer values in the range 0 - 1023, representing 10 bit R, G, B component output values. Component values may be separated by one or more commas, spaces, or tabs. The example below show LUT File contents for Line 0, Line 1, Line 2, and Line 1024, with several valid ways to separate the numbers in a line, using comma and space, tab, or only space.

- 16, 17, 17
- 17 18 18
- 19 19 21
- 1000, 1022, 1023

In the example above, the first line (Line 0) represents the output values for the case where R=0, G=0, or B=0. In other words, if the R component of a pixel is set to 0, then set R component value to 16. Likewise, if G is set to 0, then set G to 17. The second line (Line 1) does a similar thing for input component values equal to 1.

A simple way to construct a LUT file is to go to user linear in Control Panel and make some modifications, then click export and you will have a .cube file. You can then either import that LUT on a different workstation, or else use a text editor to make manual adjustments if desired.

Presets Screen



After configuring the AJA Control Panel screens, you can then save all your settings as a snapshot for later recall, called a preset. In this way, you can organize presets for all your typical tasks, eliminating manual reconfiguration.

Saving, Loading and Deleting Presets

To save a preset, simply go to the Presets screen and click “Save Preset”. A dialog will be presented asking you for a file name. Enter a meaningful name and click “OK”. Thereafter the preset will be available under the Control Panel “Presets” list.

From the Presets screen you can manage your collection of presets easily. To Load or Delete a stored preset, just select it with your mouse and then click the “Load Preset” or “Delete” button respectively .

Transferring Saved Presets

If you want to use a saved Preset on another workstation, you can simply copy the file on removable storage and install it at the new location. The Preset files are stored at:

Mac OS Preset Files Storage Location

- From the Finder, hold down the Option key (to display the Library directory) and click on Go/Library/Application Support/AJA/<device name>/Presets/

Windows Preset Files Storage Location

- c:\Users\<username>\AppData\Local\AJA\Control Panel\<device name>\Presets\

Reset to Default

When you click the "Reset Device" button the Default User Preference file will be deleted and AJA Control Panel will do one of the following:

- If a Default Global Preference is found, it is loaded and the device is set to this state.
- If a Default Global Preference file is not found, "factory defaults" are loaded and the device is set to this state.

NOTE: See "Default Preferences" on page 20 for more information.

Erase all Prefs

For technical support purposes you may be required to remove the current Preference settings. Clicking on the "Erase all Prefs" button deletes the current Default User Preference file without accessing a Default Global Preference file, if one exists. Current AJA device settings are not altered, but changing any setting will immediately regenerate a Default User Preference file with the changed settings.

NOTE: Clicking on the AJA Control Panel Erase All Prefs button does NOT delete an existing Global Preference file from that shared location nor will it reset the IP Config settings.

Info Screen

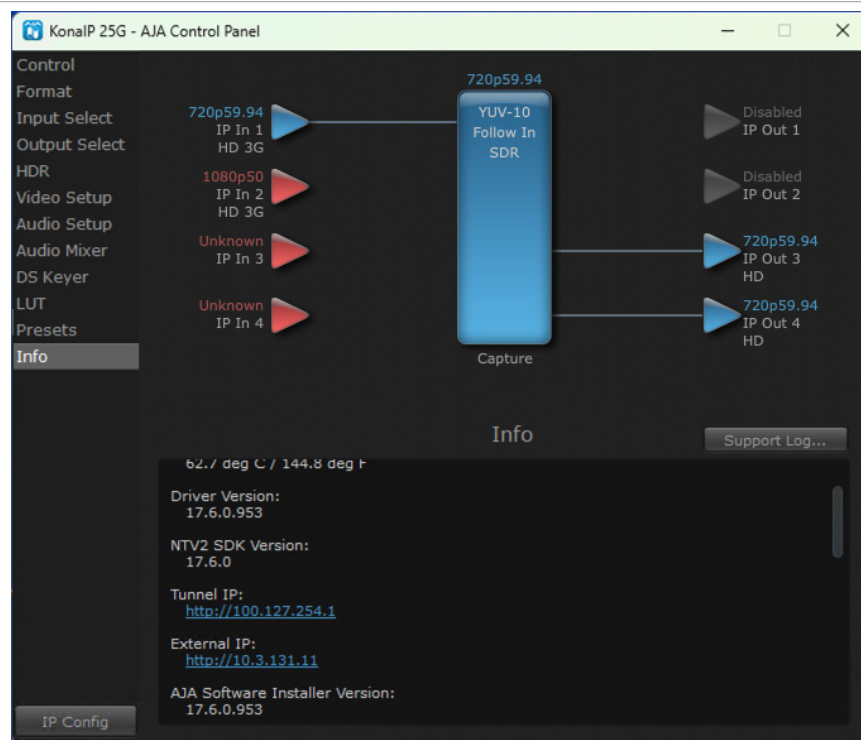

The Info screen shows the KONA IP25 software files that have been installed on your system. This information may be needed if you talk to an AJA Customer Service representative to determine if files are missing or need updating.

The Info screen also provides IP addresses, such as the External IP address (the URL of the internal WebUI) and Tunnel IP, that may be needed for network configuration. See "*KONA IP25 Card Access for Configuration and Control*" on page 10 for details on various connection methods.

IP Config

Clicking on the IP Config button in the bottom left corner of the UI launches the Control Panel AV IP configuration dialog where you can specify various IP settings.

Inputs Tab

Multicast View

Provides manual entry of all multicast settings. If an SDP is delivered to the receiver, the entries shall be loaded from SDP. Entries can be overwritten and will not automatically reapply previous settings, unless the SDP is reapplied. All settings must be accurate to receive the incoming multicast stream.

Figure 15. IP Config: Inputs Tab - Multicast View Selected

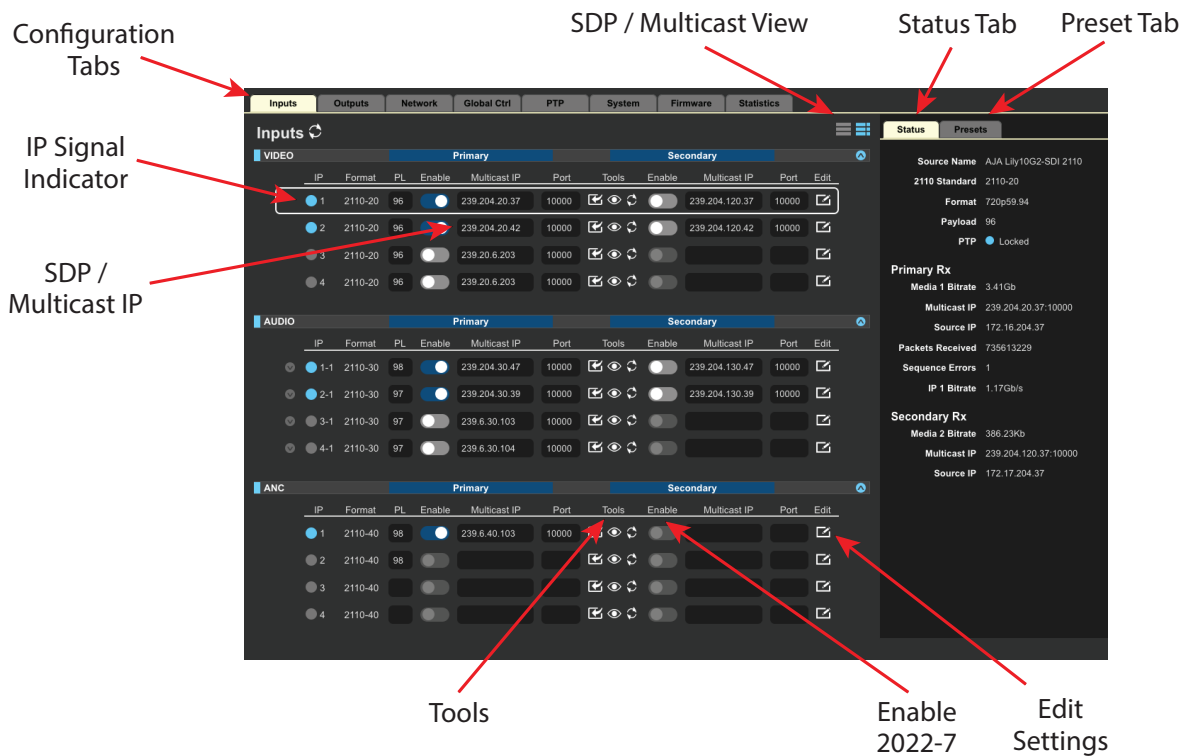

PL - Presents Payload ID received from SDP.

Primary Port - Manual Port entry for Primary Multicast to be received.

Secondary Multicast IP - Manual IP entry for Secondary Multicast to be received.

Secondary Port - Manual Port entry for Secondary Multicast to be received.



IP Signal Indicator- Indicates the following:

- Valid Signal Detected and Active
- Signal Inactive or Disabled
- Nearing Maximum Bandwidth
- Duplicate Signal or Exceeded Bandwidth/'oversubscribed'



NOTE: *Oversubscribed refers to when traffic from all connected sources exceeds the available network bandwidth. When oversubscribed, all streams on the interface will be affected. It is the customer's responsibility to manage network traffic and routing, to ensure a given network path is not oversubscribed.*

SDP / Multicast IP - Displays SDP (in SDP view mode) or Multicast (in Multicast view mode) primary and secondary IP details.

SDP Status - Indicates SDP / Multicast status

- When in SDP view mode
 -  SDP is Found / Valid
 -  SDP is Not Found / Invalid
 -  Duplicate Multicast IP

Tools - The following tools are available:

-  Import SDP
-  View SDP details
-  Reset selected stream

Enable 2022-7 - Enables ST 2022-7 redundant network operations.

Edit Settings - Click on the  icon to configure various input IP settings as well as ST 2110-20 Video, ST 2110-30 Audio, and ST 2110-40 Ancillary parameters.

Status Tab

Displays configuration / status of currently selected Input IP channel.

Preset Tab

Allows Save or Recall of Input channels. You may also Export, View, or Delete selected presets.

SDP View

SDP View provides configuration when SDP URLs will be pasted into receivers to receive the multicast source.

Figure 16. IP Config: Inputs Tab - SDP View Selected

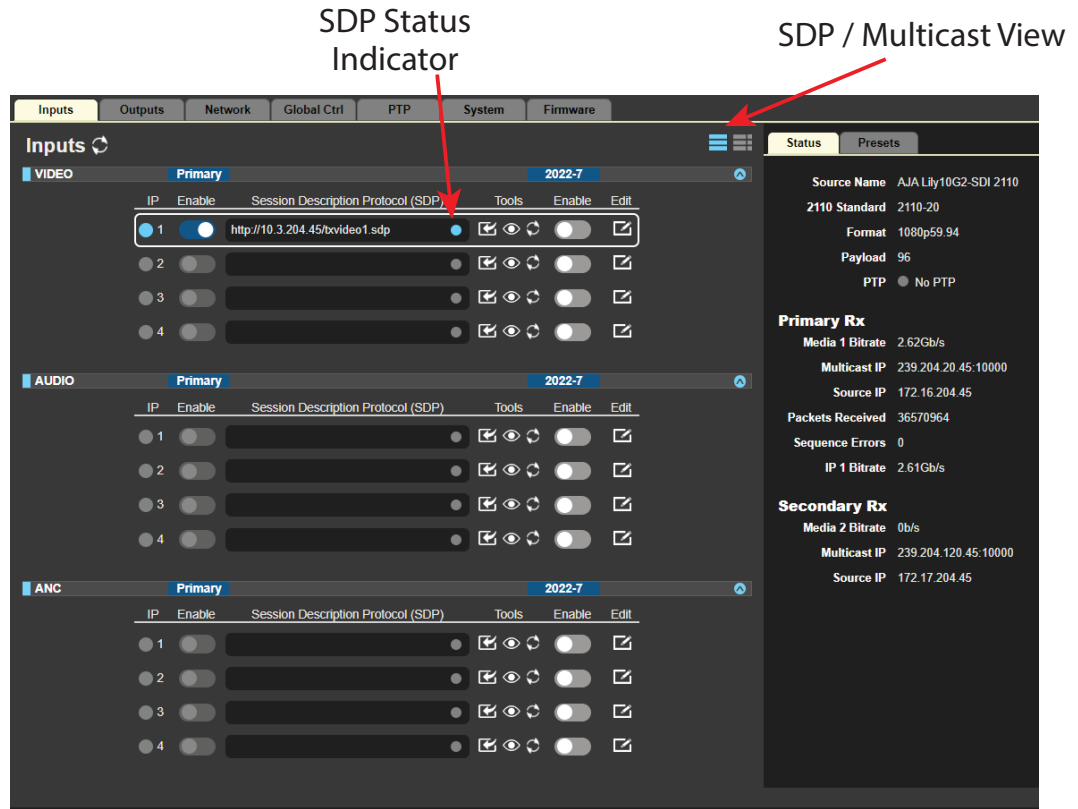

Video, Audio and Ancillary Panes on Input

Three sections provide separated Video, Audio, and Ancillary configuration. Each item in these sections has identical parameter entry windows. If external control is established (NMOS, Ember+, REST API), these windows will populate as configured externally.

There are two Inputs configuration modes to provide control in your preferred method, SDP view and Multicast View.

Settings shared between both views:

Primary Enable - Setting to enable or disable the IP input.

NOTE: When disabled, the receiver still presents as an available receiver to NMOS. If a new source is sent to the receiver, it will turn on.

Primary Session Description Protocol (SDP) - URL of SDP. Can be typed or pasted in.

Secondary Enable - Enabling will establish ST2022-7 redundancy. Note: Primary multicast must be active to enable.

Secondary Edit - Opens edit window to configure all receiver settings (p37 in IP25-R manual).

Match - Checked by default for settings read from SDP. If a setting is unchecked, the receiver will ignore that setting and attempt to receive the multicast. This is useful for troubleshooting.

For example, if the Payload ID is suspected to be incorrect in the SDP, unchecking it will allow the receiver to ignore the requirement to have a matched Payload ID in SDP and the stream.

CH1 Video SDP

Clicking on the View SDP icon (👁️) opens the CH1 Video SDP popup.

Figure 17. Inputs Tab: CH1 Video SDP Popup

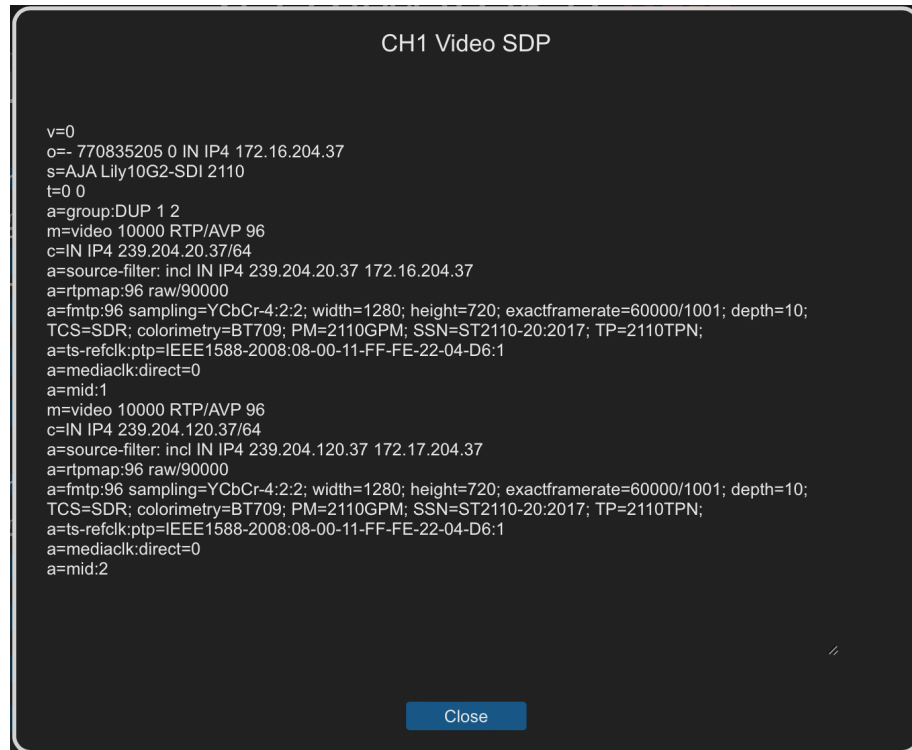

```
CH1 Video SDP

v=0
o=- 770835205 0 IN IP4 172.16.204.37
s=AJA Lily10G2-SDI 2110
t=0 0
a=group:DUP 1 2
m=video 10000 RTP/AVP 96
c=IN IP4 239.204.20.37/64
a=source-filter: incl IN IP4 239.204.20.37 172.16.204.37
a=rtpmap:96 raw/90000
a=fmtp:96 sampling=YCbCr-4:2:2; width=1280; height=720; exactframerate=60000/1001; depth=10;
TCS=SDR; colorimetry=BT709; PM=2110GPM; SSN=ST2110-20:2017; TP=2110TPN;
a=ts-refclk:ptp=IEEE1588-2008:08-00-11-FF-FE-22-04-D6:1
a=mediaclk:direct=0
a=mid:1
m=video 10000 RTP/AVP 96
c=IN IP4 239.204.120.37/64
a=source-filter: incl IN IP4 239.204.120.37 172.17.204.37
a=rtpmap:96 raw/90000
a=fmtp:96 sampling=YCbCr-4:2:2; width=1280; height=720; exactframerate=60000/1001; depth=10;
TCS=SDR; colorimetry=BT709; PM=2110GPM; SSN=ST2110-20:2017; TP=2110TPN;
a=ts-refclk:ptp=IEEE1588-2008:08-00-11-FF-FE-22-04-D6:1
a=mediaclk:direct=0
a=mid:2

Close
```

SDP is the Session Description Parameter, which contains the configuration details of a sender or receiver. SDP allows for automated configuration of a receiver to accept the senders signal.

Video Input (2110-20)

Clicking on IP 1's 'Edit' opens the CH1 Video Input window.

CAUTION: Any changes made in this window will impact the input stream. This window can be useful for making manual changes or troubleshooting. Proceed with caution.

Figure 18. Inputs Tab: CH1 Video Input Popup Window

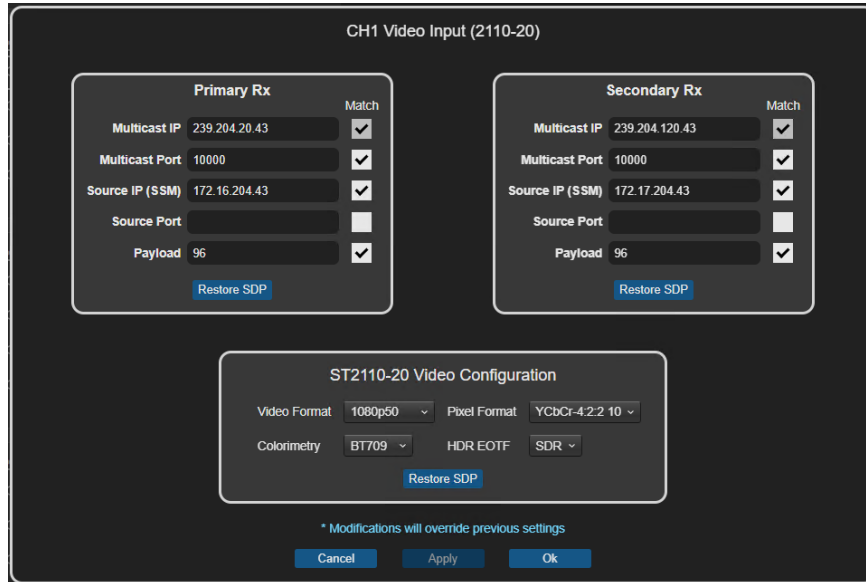

Primary & Secondary Rx

Multicast IP - Multicast source IP.

Multicast Port - Multicast source Port

Source IP (SSM) - Senders IP. Utilized when Source Specific Multicast is implemented

Source Port - Sender's port.

Payload - Payload ID. Must match between SDP and stream.

Restore SDP Button - If any settings are changed, selecting 'Restore SDP' will read the SDP and reapply the settings.

ST2110-20 Video Configuration

Video Format - Provides status of current Video format as read from SDP and provides manual selection, if needed.

Colorimetry - Provides status of current Colorimetry setting as read from SDP and provides manual selection, if needed.

Pixel Format - Provides status of current Pixel format as read from SDP and provides manual selection, if needed.

HDR EOTF - Provides status of current HDR setting as read from SDP and provides manual selection, if needed

Restore SDP Button - Restores to settings as read from SDP.

Audio Input (2110-30)

Clicking on IP 2's 'Edit' opens the CH2 Audio Input window.

Figure 19. Inputs Tab: CH2-1 Audio Input Popup Window

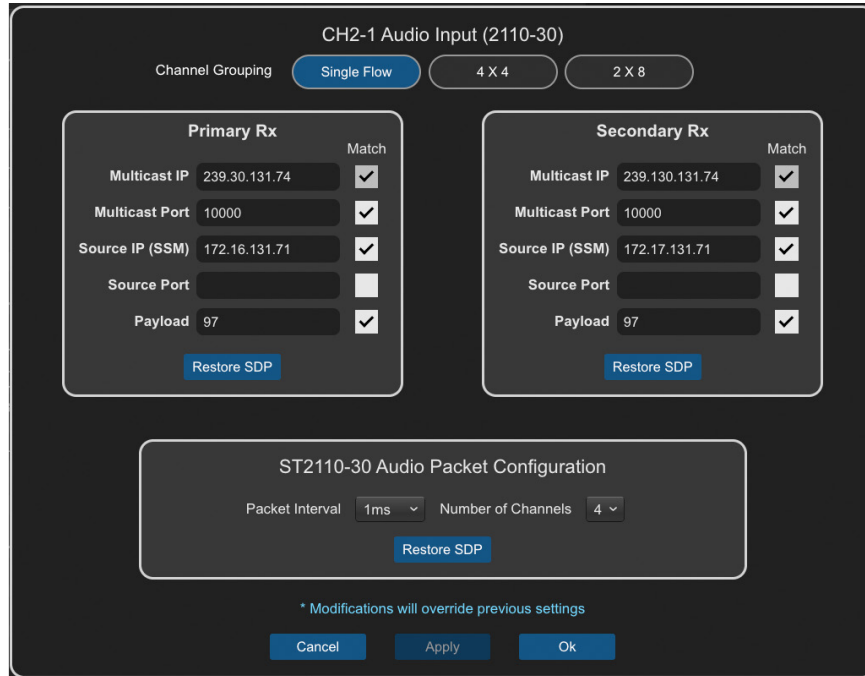

Multiple ST2110-30 Audio Groups on Inputs

The KONA IP25 supports multiple ST2110-30 Audio modes on Inputs for expanding audio flows and channel counts, as needed in some infrastructures. Three modes are available:

- Single Flow (default): Supports up to 16 channels with 125us and up to 8 channels with 1ms timing.
- 4x4: Supports 4x ST2110-30 audio flows with 4 channels each @ 125us or 1ms timing, totaling 16 channels.
- 2x8: Supports 2x ST2110-30 audio flows with 8 channels each @ 125us or 1ms timing, totaling 16 channels.

To change the mode, select 'Edit' on the first stream of the audio group. The window will show the three modes at the top. When the desired mode is selected, the audio stream configuration will be available only for the valid stream numbers.

When 4x4 or 2x8 modes are selected, Input audio streams are named 1-1, 1-2, 1-3, etc. to facilitate the grouping of multiple audio streams to a video. When these modes are selected, a selection arrow to the left of the stream expands the view of the audio streams, when needed. See ["Inputs Tab" on page 42](#).

ANC Input (2110-30)

Clicking on IP 1's 'Edit' opens the CH1 ANC Input window.

NOTE: The KONA IP25 retail version only supports ANC 1 on Input.

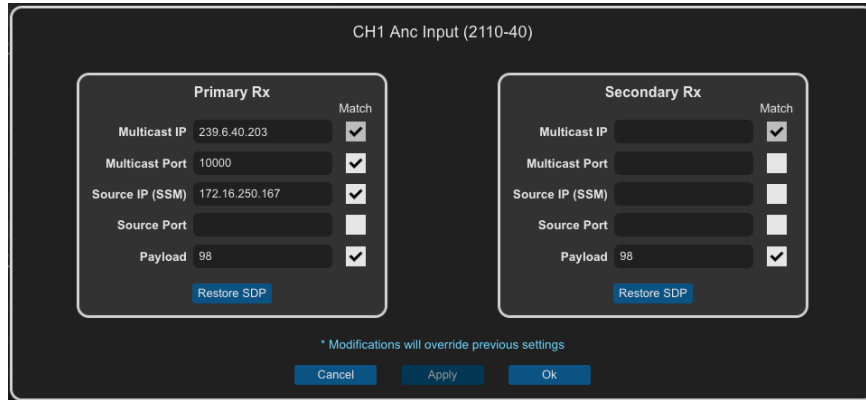

Figure 20. Inputs Tab: CH1 ANC Input Popup Window



Outputs Tab

The Output Tab gives information and configuration options for the KONA IP25's output settings via .sdp file or manual configuration.

The following additional controls are available for Output:

-  Designates specified channel as Media and copies details to clipboard.
-  Designates specified channel as Control and copies details to clipboard.

When selected, control color will change to light blue.

NOTE: The KONA IP25 retail version only supports Channels 3 and 4 on Output.

Status Tab

Displays configuration / status of currently selected Output IP channel.

Preset Tab

Allows Save or Recall of Output channels. You may also Export, View, or Delete selected presets.

Video, Audio and Ancillary Panes on Output

Figure 21. IP Config: Outputs Tab - SDP View Selected

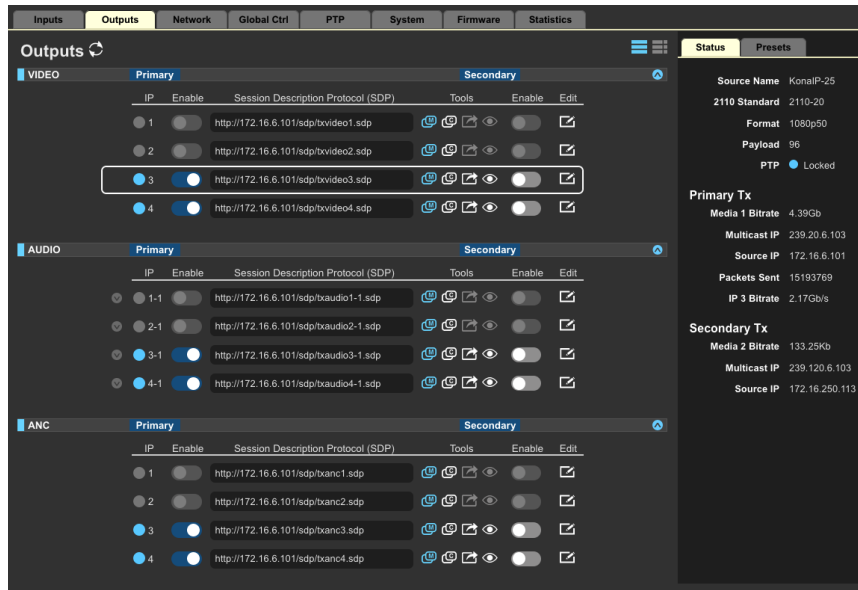

Figure 22. IP Config: Outputs Tab - Multicast View Selected

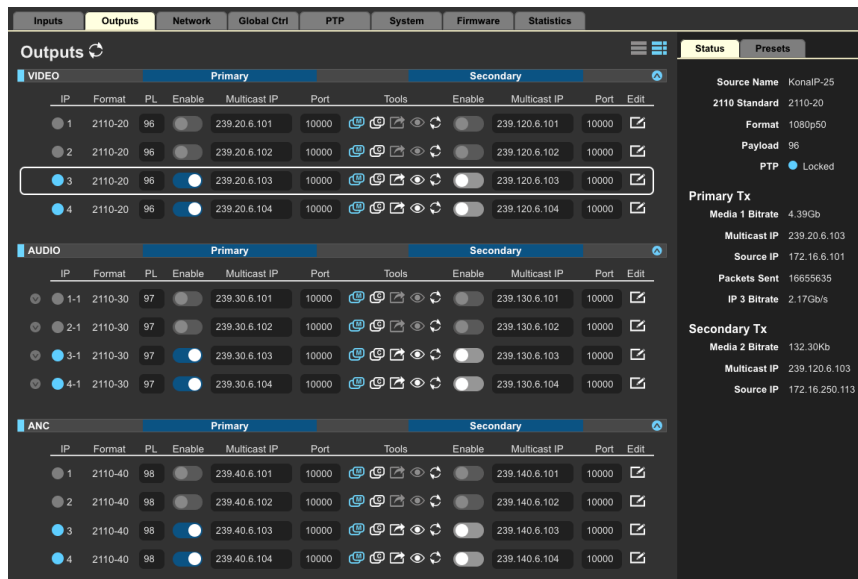

Figure 23. Outputs Tab: CH1 Video Output Popup Window

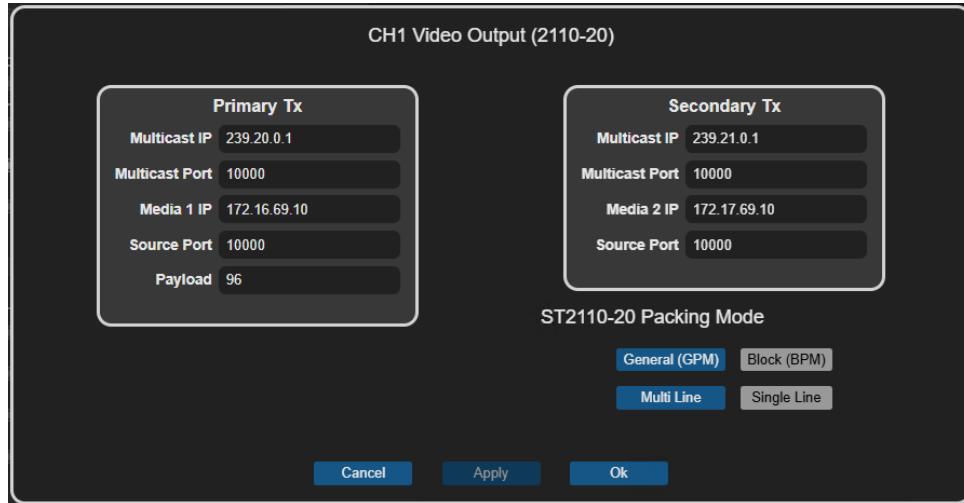
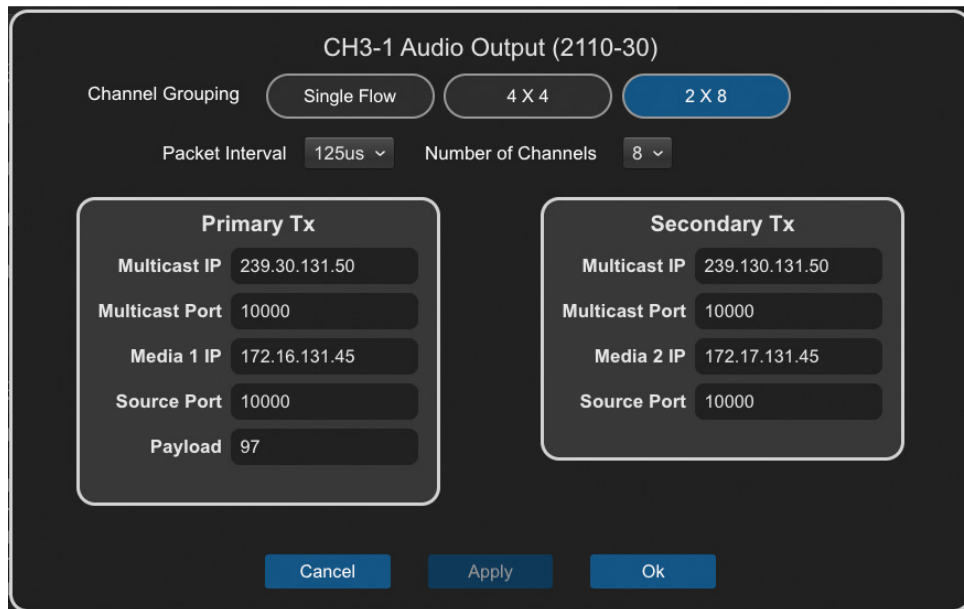

Figure 24. Outputs Tab: CH3-1 Audio Output Popup Window



Multiple ST2110-30 Audio Groups on Outputs

The KONA IP25 supports multiple ST2110-30 Audio modes on Outputs for expanding audio flows and channel counts, as needed in some infrastructures. Three modes are available:

- Single Flow (default): Supports up to 16 channels with 125us and up to 8 channels with 1ms timing.
- 4x4: Supports 4x ST2110-30 audio flows with 4 channels each @ 125us or 1ms timing, totaling 16 channels.
- 2x8: Supports 2x ST2110-30 audio flows with 8 channels each @ 125us or 1ms timing, totaling 16 channels.

To change the mode, select 'Edit' on the first stream of the audio group. The window will show the three modes at the top. When the desired mode is selected, the audio stream configuration will be available only for the valid stream numbers.

When 4x4 or 2x8 modes are selected, Output audio streams are named 1-1, 1-2, 1-3, etc. to facilitate the grouping of multiple audio streams to a video. When these modes are selected, a selection arrow to the left of the stream expands the view of the audio streams, when needed. See ["Outputs Tab" on page 48](#).

Figure 25. Outputs Tab: CH3 ANC Output Popup Window

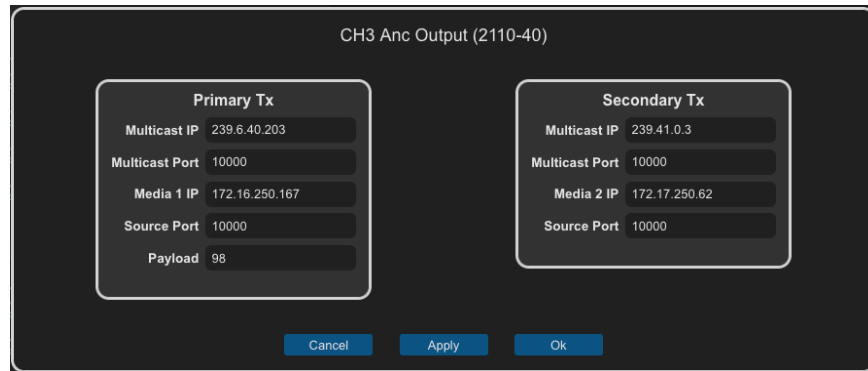

Network Tab

The Network Tab gives information about the KONA IP25's network settings, and allows changing them to meet your network environment. The Media 1, Media 2, and Control Networks each have their own respective controls and status information.

- Media 1: SFP cage closest to RJ45. Typically Primary network. Supports ST 2110, PTP, and external control.
- Media 2: SFP cage furthest from RJ45. Typically Secondary network. Supports ST 2110, PTP, and external control.
- Control: 1GbE RJ45. Supports external control.

Figure 26. Network Tab

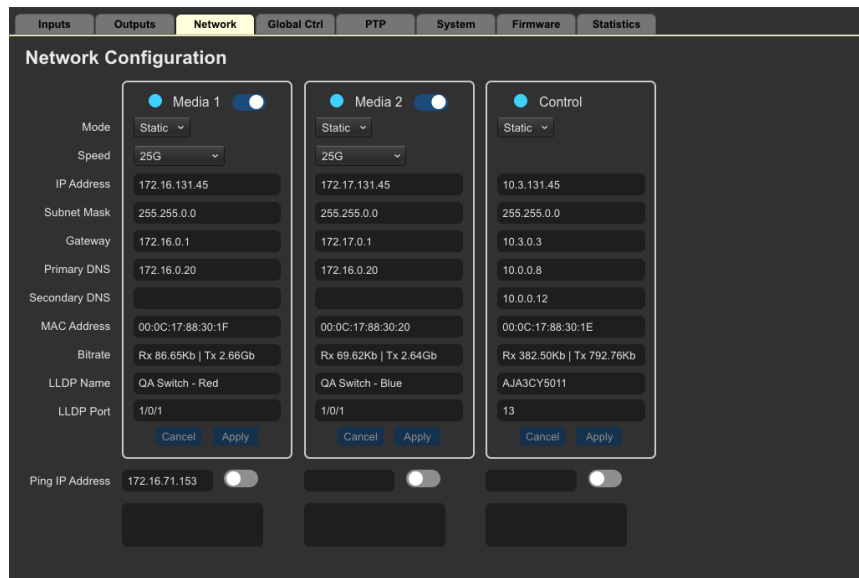

Network Tab Controls

Network status indicates the following:

- Enabled and Active
- Disabled / Inactive

- Enabled but Not Active

Media 1, Media 2 & Control Network Panes

Mode - Static or DHCP. Mode determines the type of TCP/IP network configuration to be used. DHCP enables connecting to the network DHCP server, which assigns the IP Address, Netmask, and Gateway automatically. Static lets you set these parameters manually.

- DHCP (default) - Selects automatic IP address assignment from the DHCP server. If a DHCP server cannot be found, KONA IP25 will fall back to a link local static IP address (169.254.x.x).
- Static - Assigns a static IP address manually.

Speed (Media 1 and Media 2 networks only) - 10G, 25G, 25G FEC74 or 25G FEC108

IP Address - IP Address determines a static IP address to be used for TCP/IP networking. Consult your network administrator about how to set this value.

- If IP Address Type is set to DHCP, the IP address is set automatically by the network DHCP server.
- If IP Address Type is set to Static, enter an IP address compatible with your LAN.
- If IP Address Type is set to DHCP and there is a DHCP failure, the IP address is set to a link local static IP address.

Subnet Mask - Subnet Mask determines the subnet mask to be used for TCP/IP networking.

- Use a subnet mask compatible with your LAN. This is only needed for Static IP configurations. The factory default Subnet Mask is 255.255.255.0.
- If IP Address Type is set to DHCP, the Subnet Mask is set by the DHCP server and cannot be changed by the user

Gateway - Gateway determines the gateway or router used on your LAN for TCP/IP networking. Without a properly configured default gateway (whether you have a router/gateway or not), your KONA IP25 will be unable to see other KONA IP25 devices on the network, although you may still be able to control this KONA IP25 via a web browser. Also, without a proper gateway defined, the discovery feature on the Network web page will not list other units on the network.

- Use a default gateway or router address. This is only needed for Static IP configurations.
- If IP Address Type is set to DHCP, the Default Gateway is set by the DHCP server and cannot be changed by the user.

Primary and Secondary DNS Servers - In DHCP mode, reports the current DNS Server IP addresses. In Static mode, allows entry of DNS Server IP addresses.

CAUTION: *If DNS servers are not present or have incorrectly entered IPs, then wherever KONA IP25 specifies machines by name the names won't work, although numeric IP addresses will still work.*

CAUTION: *When using Static IP addressing for KONA IP25, be sure to also enter a valid DNS server address in the "Primary DNS Server" field. If the DNS Server address is not entered or is invalid, URLs in streaming destinations won't work and an Alarm will be displayed:*

MAC Address - Reports the connected KONA IP25's Media Access Control Address.

Bitrate - Shows the RX/TX bitrates for all data on the port. Media TX may have some usage due to connections such as PTP

LLDP Name - Presents Link Layer Description Protocol Name.

LLDP Port - Link Layer Discovery Protocol: allows network devices to discover each other's identity, capabilities, and configuration by sending Type-Length-Value (TLV) packets on the data link layer.

Ping IP Address - Troubleshooting tool to find IPs on the network. When enabled, it will continuously ping the entered IP and show status of response. Mode selection for DHCP or Static IP configuration.

Global CTRL Tab

The Global Control Tab gives information and configuration options for the KONA IP25's NMOS and Ember+ settings. See "[NMOS](#)" on page 7 for information on NMOS. See "[Ember+](#)" on page 7 for information on Ember+.

Figure 27. Global Control Tab

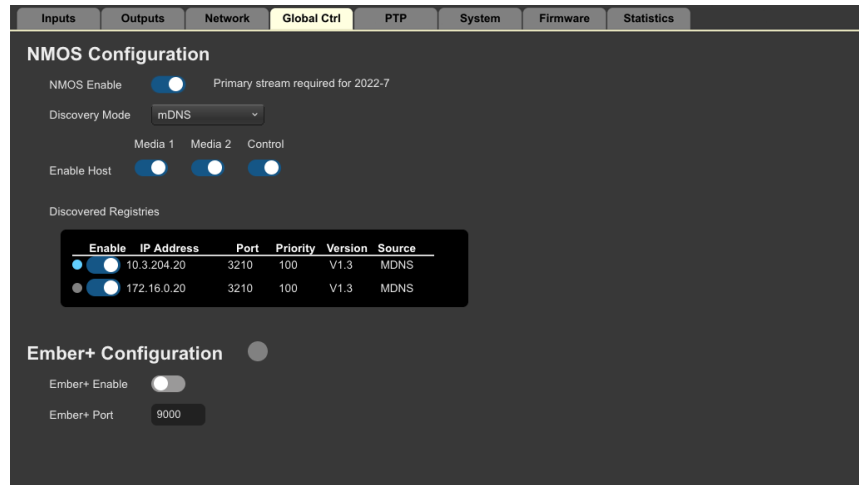

NMOS Configuration

The following controls are available for NMOS configuration with the KONA IP25. AJA recommends consulting with your IT Administrator to properly configure and set up use of NMOS with your KONA IP25.

NMOS Enable - Enable/Disable NMOS for the KONA IP25.

Discovery mode - Sets mode for discovery of available NMOS registries.

Enable Host - Enables/Disables Media 1, Media 2, Control hosts.

Discovered Registries - Displays available NMOS registry details.

Enabled and available active registries will be marked with a indicator and unavailable registries will be marked with an indicator. Disabled registries will appear in a Disabled Registries window with a delete option.)

Figure 28. Discovered Registries

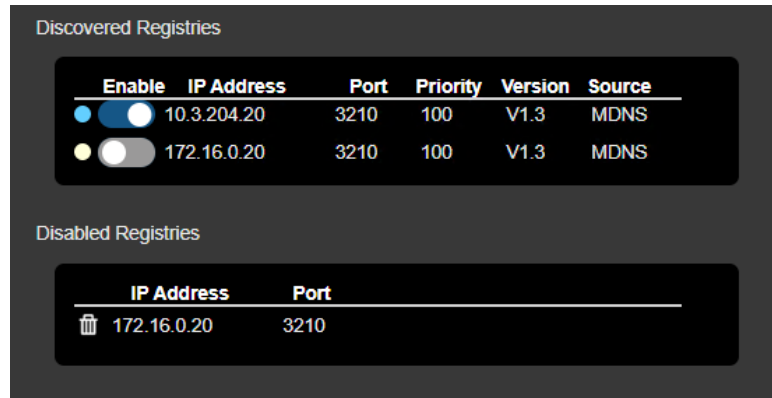

With NMOS enabled, KONA IP25 receivers support master_enable commands, as defined in the IS-05 specification.

When a master_enable: true is sent, the sender or receiver will be set to enabled and support programmed media. Similarly, if the sender or receiver is set to 'enable" in the UI, the it will report a master_enable:true to NMOS.

When a master_enable:false is sent, the sender or receiver will be set to disabled and media will stop on that sender or receiver. Similarly, if the sender or receiver is set to 'disable" in the UI, it will report a master_enable:false to NMOS.

If ST 2022-7 is enabled, both senders or receivers will abide to the same rules.

Ember+ Configuration

The following controls are available for Ember+ configuration with the KONA IP25. AJA recommends consulting with your IT Administrator to properly configure and set up use of Ember+ with your KONA IP25.

Ember+ Enable - Enable/Disable Ember+ for the KONA IP25.

Ember+ status indicates the following:

- Ember+ Enabled and Detected
- Ember+ Disabled or Not Detected

NOTE: When Ember+ is enabled, a primary stream is required for 2022-7.

Ember+ Port - Allows specification of port to use.

PTP Tab

The PTP (Precision Time Control) Tab gives information and configuration options for the KONA IP25's PTP settings.

Figure 29. PTP Tab

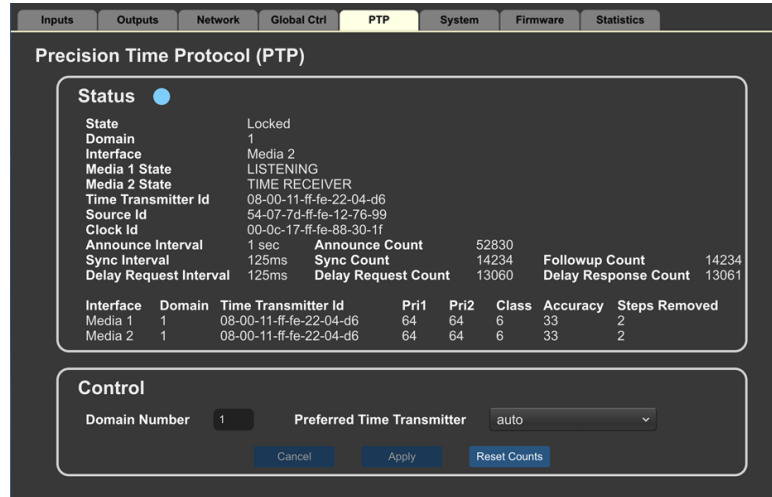

PTP Control Pane

Domain Number - Select domain number. 0 and 127 are reserved and should not be used.

Preferred Time Transmitter - (Select Preferred Time Transmitter from available sources. Click Apply to apply modified Domain Number or Preferred Time Transmitter selections. Click Reset Controls to restore to default settings

Cancel Button - Reverts any not-applied changes to previous settings, within PTP Pane.

Apply Button - Applies any changes made in the PTP Pane.

Reset Counts - Resets incrementing Counts in PTP pane for Announce Count, Sync Count, Delay Request Count, Follow Up Count, Delay Response Count.

System Tab

The System Tab gives information about the KONA IP25's host system.

Figure 30. System Tab



System Tab Controls

Host Name - Click the Change button to enter a custom name for this KONA IP25, which can be useful if more than one KONA IP25 is being used in a production. This name appears in the Network tab of AJA devices connected on that network.)

Product - Opens KONA IP25 page on the AJA website for an overview of the product.

Support - Opens KONA IP25 page on the AJA website and presents Contact Support information.

About - Opens About KONA IP25 information panel.

Factory Settings - Resets your KONA IP25 to factory settings.

NOTE: Factory reset clears user configurations and cannot be undone.

Support Log - Generate and download a support log for your KONA IP25.
This may be required when working with your AJA Customer Support representative.

Receiver Classification - Used to specify difference in timing or synchronization between two or more signals or data streams within a network. Default is Low-Skew @ 10ms.

NOTE: When changing Receiver Classification settings, it is recommended to disable then re-enable primary and secondary Input streams.

Video+KEY Mode - Used to select between 4:2:2 10Bit YCbCr and 4:0:0 10Bit (Key in SDP).

NOTE: In the current release, Video + KEY is ONLY available for Playback/TX.

Firmware Tab

The Firmware Tab gives information about the KONA IP25's firmware, and is used to update its firmware. A restart is required after the firmware is loaded.

Figure 31. Firmware Tab

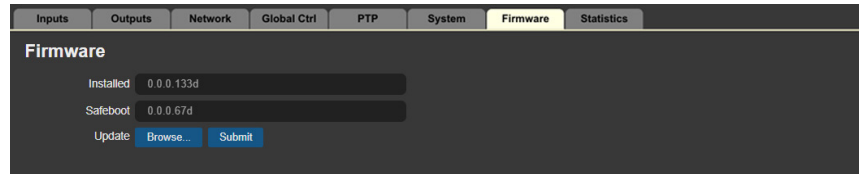

Downloading and Installing Updated Firmware

The Update Firmware window allows you to download and install a firmware update from AJA.

To Download and Install Updated Firmware

1. Click **Browse**, locate the KONA IP25 License firmware file and click **Upload**.
2. Click **Submit**. A message appears indicating the progress of the update.
3. A restart is required after the firmware is loaded, which can be accomplished by clicking that message's **Restart** button.
4. The KONA IP25's web connection will disconnect and then reconnect with the updated firmware.

Statistics Tab

The round icon at top of the Media 1, Media 2 and Control panes will indicate network status as follows:



-  Enabled and Active
-  Disabled / Inactive
-  Enabled but Not Active

Figure 32. Statistics Tab



Media 1 and Media 2 Network Statistics

Mac Address - Reports the connected KONA IP25's Media Access Control Address.

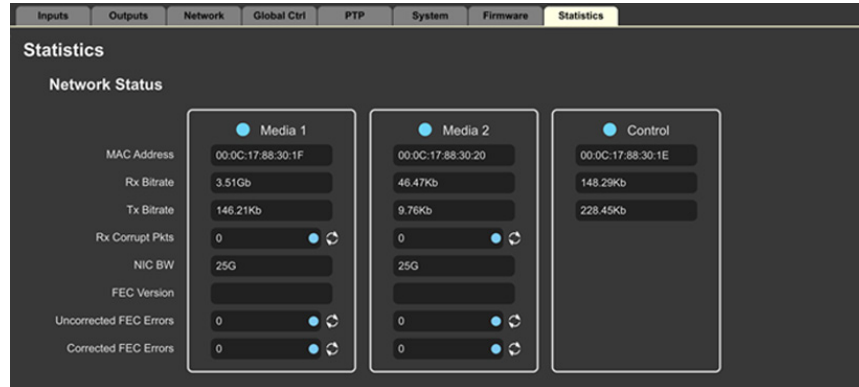
Rx Bitrate - Shows the RX bitrates for all data on the port.

Tx Bitrate - Shows the TX bitrate for all data on the port. Media TX may have some usage due to connections such as PTP.

Rx Corrupt Pkts - Provides incrementing count of corrupt packets. Reset button returns count to 0. Status is indicated as follows:

- No Rx Corrupt Packets
- Number of Rx Corrupt Packets

NIC BW - Status of programmed NIC bandwidth.

FEC Version - Status of FEC version active: Firecode or Reed Solomon.

Uncorrected FEC Errors - Status of Uncorrected FEC errors. Only active when FEC is enabled. Reset button returns count to 0. Status is indicated as follows:

- No Uncorrected FEC Errors
- Number of Uncorrected FEC Errors

Corrected FEC Errors - Status of Corrected FEC errors. Only active when FEC is enabled. Reset button returns count to 0. Status is indicated as follows:

- No Corrected FEC Errors
- Number of Corrected FEC Errors

Control Network Statistics

Mac Address - Reports the connected KONA IP25's Media Access Control Address.

Rx Bitrate - Shows the RX bitrate for all data on the port.

Tx Bitrate - Shows the TX bitrate for all data on the port. The Statistics Tab provides information about the KONA IP25's network status.

Appendix A – Specifications

KONA IP25 Tech Specs

Video Formats YCbCr 4:2:2 10-bit

- (4K) 4096 x 2160p 23.98, 24, 25, 29.97, 30, 50, 59.94, 60
- (UltraHD) 3840 x 2160p 23.98, 24, 25, 29.97, 30, 50, 59.94, 60
- (2K) 2048 x 1080p 23.98, 24, 25, 29.97, 30, 50, 59.94, 60
- (HD) 1920 x 1080p 23.98, 24, 25, 29.97, 30, 50, 59.94, 60
- (HD) 1920 x 1080i 50, 59.94
- (HD) 1280 x 720P 50, 59.94, 60

NOTE: High Frame Rate capabilities are dependent on host system attributes.

Video Formats RGB 4:4:4 12-bit

- (4K) 4096 x 2160p 23.98, 24, 25, 29.97, 30, 50, 59.94, 60
- 2048 x 1080p 23.98, 24, 25, 29.97, 30, 50, 59.94, 60
- (HD) 1920 x 1080p 23.98, 24, 25, 29.97, 30, 50, 59.94, 60

NOTE: High Frame Rate capabilities are dependent on host system attributes.

Media Transport Interfaces (In-Band)

- Uncompressed media (ST 2110-20, 30, 40)
- PTP
- Configuration & Control
- 2x SFP28 Cages (redundant only) - SFPs not included
- Supports 10 GigE and 25 GigE SFPs with FEC

RJ-45 1 GigE Interface (Out-Of-Band)

- Configuration & Control

Input Uncompressed IP

- SMPTE ST 2110-20 Video
- YCbCr 4:2:2 10-bit
- RGB 4:4:4 12-bit
- 4-channel input*
- Rx support for Narrow and Wide Senders
- RX support for Class-A, B, C, D ST 2022-7 redundancy

* Format and application dependent

SMPTE ST 2110-30 Audio

- Up to 16 stream input*
- 1, 2, or 4 streams per video*
- Up to 16-channel audio per stream, 24-bit per channel, 48 kHz synchronous*
- 1ms and 125us timing

* Application dependent

SMPTE ST 2110-40 Ancillary

- 4x stream input*

* Application dependent

Output Uncompressed IP

- SMPTE ST 2110-20
 - YCbCr 4:2:2 10-bit
 - RGB 4:4:4 12-bit
 - 4-channel output*
 - Tx support for ST 2022-7
 - Tx senders are Narrow Gapped

* Format dependent

SMPTE ST 2110-30 Audio

- Up to 16 stream output*
- 1, 2, or 4 streams per video*
- Up to 16-channel audio per stream, 24-bit per channel, 48 kHz synchronous*
- 1ms and 125us timing

* Application dependent

SMPTE ST 2110-40 Ancillary

- 4x stream output

SDR/HDR

- SDP file support for SDR/HDR Transfer Characteristics, Colorimetry, and Luminance

Discovery, Registration and Control

- NMOS Tx/Rx support according to standards IS-04 v1.3 and IS-05 v1.1
- LLDP
- In-Band and Out-of-Band
- L2, L3 with SSM
- IGMP v2, v3

IP Clock

- PTPv2 ST 2059-2 / IEEE 1588-2008
- In-Band only

Electrical Interface

- 8-lane PCIe 4.0

Noise

- <50dBA (A-weighted at 1m in free air)
- Fan is rated at 33.1dBA

Regulatory Compliance

- UL 62368-1: 2014
- CSA-C22.2 62368-1-14
- EN 62368-1: 2014 + A11
- RoHS 3

Size (w x d x h)

- 247.7 x 15.9 x 98.6 mm (9.75" x 0.63" x 3.88")
- Bracket Height: 127 mm (5.0")

Weight

- 0.4kg (0.6lbs)

Power

- 40W typical, 50W maximum
- PC Internal or PCI Aux Power Connector (6 pin 2x3 Molex part number 45558-0003)

NOTE: It is recommended to provide power with PCI Aux Power connector.

Environment

- Safe Operating Temperature Range: 0 to 40 C (32 to 104 F)
- Safe Storage Temperature (Power OFF): -40 to 60 C (-40 to 140 F)
- Operating Relative Humidity: 10-90% noncondensing
- Operating Altitude: <3,000 meters (<10,000 feet)

Appendix B – Safety & Compliance

Class A Interference Statement

This equipment has been tested and found to comply with the limits for a Class A digital device, pursuant to Part 15, Subpart B of the FCC Rules. These limits are designed to provide reasonable protection against harmful interference in a residential installation. This equipment generates, uses, and can radiate radio frequency energy and, if not installed and used in accordance with the instructions, may cause harmful interference to radio communications. However, there is no guarantee that interference will not occur in a particular installation. If this equipment does cause harmful interference to radio or television reception, which can be determined by turning the equipment off and on, the user is encouraged to try to correct the interference by one or more of the following measures:

- Reorient or relocate the receiving antenna.
- Increase the separation between the equipment and receiver.
- Connect the equipment into an outlet on a circuit different from that to which the receiver is connected.
- Consult the dealer or an experienced radio/TV technician for help.

FCC Caution

This device complies with Part 15 of the FCC Rules. Operation is subject to the following two conditions: (1) This device may not cause harmful interference, and (2) this device must accept any interference received, including interference that may cause undesired operation.

Canadian ICES Statement

Canadian Department of Communications Radio Interference Regulations

This digital apparatus does not exceed the Class A limits for radio-noise emissions from a digital apparatus as set out in the Radio Interference Regulations of the Canadian Department of Communications. This Class A digital apparatus complies with Canadian ICES-003.

Règlement sur le brouillage radioélectrique du ministère des Communications

Cet appareil numérique respecte les limites de bruits radioélectriques visant les appareils numériques de classe A prescrites dans le Règlement sur le brouillage radioélectrique du ministère des Communications du Canada. Cet appareil numérique de la Classe A est conforme à la norme NMB-003 du Canada.

European Union, European Free Trade Association (EFTA) and United Kingdom Regulatory Compliance

This equipment may be operated in the countries that comprise the member countries of the European Union, European Free Trade Association and the United Kingdom. These countries, listed in the following paragraph, are referred to as The European Community throughout this document:

AUSTRIA, BELGIUM, BULGARIA, CROATIA, CZECH REPUBLIC, DENMARK, ESTONIA, FINLAND, FRANCE, GERMANY, GREECE, HUNGARY, ICELAND, IRELAND, ITALY, LATVIA, LIECHTENSTEIN, LITHUANIA, LUXEMBOURG, MALTA, NETHERLANDS, NORWAY, POLAND, PORTUGAL, REPUBLIC OF CYPRUS, ROMANIA, SLOVAK REPUBLIC, SLOVENIA, SPAIN, SWEDEN, SWITZERLAND, UNITED KINGDOM

Declaration of Conformity

Marking by these symbols indicates compliance with the Essential Requirements of the EMC Directive of the European Union 2014/30/EU.



This equipment meets the following conformance standards:

Safety

EN 62368-1: 2014 + A11 (T-Mark License),
IEC 62368-1: 2014 (CB Scheme Report/Certificates)

Emissions

EN 55032: 2015 + A11: 2020, CISPR 32: 2015 + A1: 2019,
EN 61000-3-2: 2019 + A1: 2021 + A2: 2024, EN 61000-3-3: 2013 + A1: 2019 + A2: 2021

Immunity

EN 55035: 2017 + A11: 2020, CISPR 35: 2017, EN 61000-4-2:2009,
EN 61000-4-3: 2020,
EN 61000-4-4: 2012, EN 61000-4-5: 2014 +A1: 2017, EN 61000-4-6: 2023,
EN 61000-4-11: 2020

The product is also licensed for additional country specific standards as required for the International Marketplace.



Warning! This is a Class A product. In a domestic environment, this product may cause radio interference, in which case, the user may be required to take appropriate measures.

Achtung! Dieses ist ein Gerät der Funkstörgrenzwertklasse A. In Wohnbereichen können bei Betrieb dieses Gerätes Rundfunkstörungen auftreten, in welchen Fällen der Benutzer für entsprechende Gegenmaßnahmen verantwortlich ist.

Attention! Ceci est un produit de Classe A. Dans un environnement domestique, ce produit risque de créer des interférences radioélectriques, il appartiendra alors à l'utilisateur de prendre les mesures spécifiques appropriées.

Recycling Notice



This symbol on the product or its packaging indicates that this product must not be disposed of with your other household waste. Instead, it is your responsibility to dispose of your waste equipment by handing it over to a designated collection point for the recycling of waste electrical and electronic equipment. The separate collection and recycling of your waste equipment at the time of disposal will help conserve natural resources and ensure that it is recycled in a manner that protects human health and the environment. For more information about where you can drop off your waste for recycling, please contact your local authority, or where you purchased your product.

Korea KCC Compliance Statement

사 용 자 안 내 문

이 기기는 업무용 환경에서 사용할 목적으로 적합성평가를 받은 기기로서 가정용 환경에서 사용하는 경우 전파간섭의 우려가 있습니다.

Taiwan Compliance Statement

警告使用者：
這是甲類的資訊產品，在居住的環境中使用時，可能會造成射頻干擾，在這種情況下，使用者會被要求採取某些適當的對策。

This is a Class A product based on the standard of the Bureau of Standards, Metrology and Inspection BSMI CNS 15936:2016, Class A. In a domestic environment this product may cause radio interference in which case the user may be required to take adequate measures.

Japan Compliance Statement

この装置は、クラスA情報技術装置です。この装置を家庭環境で使用すると電波妨害を引き起こすことがあります。この場合には使用者が適切な対策を講ずるよう要求されることがあります。 VCCI-A

This is a Class A product based on the standard of the VCCI Council (VCCI 32: 2016). If this equipment is used in a domestic environment, radio interference may occur, in which case, the user may be required to take corrective actions.

Translated Warning and Caution Messages

The following caution statements, warning conventions, and warning messages apply to this product and manual.



Warning Symbol



Caution Symbol

Before Operation Please Read These Instructions



Warning! Read and follow all warning notices and instructions marked on the product or included in the documentation.

Avertissement! Lisez et conformez-vous à tous les avis et instructions d'avertissement indiqués sur le produit ou dans la documentation.

Warnung! Lesen und befolgen Sie die Warnhinweise und Anweisungen, die auf dem Produkt angebracht oder in der Dokumentation enthalten sind.

¡Advertencia! Lea y siga todas las instrucciones y advertencias marcadas en el producto o incluidas en la documentación.

Aviso! Leia e siga todos os avisos e instruções assinalados no produto ou incluídos na documentação.

Avviso! Leggere e seguire tutti gli avvisi e le istruzioni presenti sul prodotto o inclusi nella documentazione.



Warning! Do not use this device near water and clean only with a dry cloth.

Avertissement! N'utilisez pas cet appareil près de l'eau et nettoyez-le seulement avec un tissu sec.

Warnung! Das Gerät nicht in der Nähe von Wasser verwenden und nur mit einem trockenen Tuch säubern.

¡Advertencia! No utilice este dispositivo cerca del agua y límpielo solamente con un paño seco.

Aviso! Não utilize este dispositivo perto da água e limpe-o somente com um pano seco.

Avviso! Non utilizzare questo dispositivo vicino all'acqua e pulirlo soltanto con un panno asciutto.



Warning! Do not block any ventilation openings. Install in accordance with the manufacturer's instructions.

Avertissement! Ne bloquez aucune ouverture de ventilation. Suivez les instructions du fabricant lors de l'installation.

Warnung! Die Lüftungsöffnungen dürfen nicht blockiert werden. Nur gemäß den Anweisungen des Herstellers installieren.

¡Advertencia! No bloquee ninguna de las aberturas de la ventilación. Instale de acuerdo con las instrucciones del fabricante.

Aviso! Não obstrua nenhuma das aberturas de ventilação. Instale de acordo com as instruções do fabricante.

Avviso! Non ostruire le aperture di ventilazione. Installare in conformità con le istruzioni del fornitore.



Warning! Do not install near any heat sources such as radiators, heat registers, stoves, or other apparatus (including amplifiers) that produce heat.

Avertissement! N'installez pas l'appareil près d'une source de chaleur telle que des radiateurs, des bouches d'air de chauffage, des fourneaux ou d'autres appareils (amplificateurs compris) qui produisent de la chaleur.

Warnung! Nicht in der Nähe von Wärmequellen wie Heizkörpern, Heizregistern, Öfen oder anderen Wärme erzeugenden Geräten (einschließlich Verstärkern) aufstellen.

¡Advertencia! No instale cerca de fuentes de calor tales como radiadores, registros de calor, estufas u otros aparatos (incluidos amplificadores) que generan calor.

Aviso! Não instale perto de nenhuma fonte de calor tal como radiadores, saídas de calor, fogões ou outros aparelhos (incluindo amplificadores) que produzam calor.

Avviso! Non installare vicino a fonti di calore come termosifoni, diffusori di aria calda, stufe o altri apparecchi (amplificatori compresi) che emettono calore.



Warning! Unplug this device during lightning storms or when unused for long periods of time.

Avertissement! Débranchez cet appareil pendant les orages avec éclairs ou s'il est inutilisé pendant de longues périodes.

Warnung! Das Gerät ist bei Gewitterstürmen oder wenn es über lange Zeiträume ungenutzt bleibt vom Netz zu trennen.

¡Advertencia! Desenchufe este dispositivo durante tormentas eléctricas o cuando no se lo utilice por largos periodos del tiempo.

Aviso! Desconecte este dispositivo da tomada durante trovoadas ou quando não é utilizado durante longos períodos de tempo.

Avviso! Utilizzare soltanto i collegamenti e gli accessori specificati e/o venduti dal produttore, quali il treppiedi e l'esoscheletro.



Warning! Only use attachments and accessories specified and/or sold by the manufacturer.

Avertissement! Utilisez seulement les attaches et accessoires spécifiés et/ou vendus par le fabricant.

Warnung! Verwenden Sie nur Zusatzgeräte und Zubehör angegeben und / oder verkauft wurde durch den Hersteller.

¡Advertencia! Utilice solamente los accesorios y conexiones especificados y/o vendidos por el fabricante.

Aviso! Utilize apenas equipamentos/acessórios especificados e/ou vendidos pelo fabricante.

Avviso! Utilizzare soltanto i collegamenti e gli accessori specificati e/o venduti dal produttore.



Warning! Refer all servicing to qualified service personnel. Servicing is required when the device has been damaged in any way, such as power-supply cord or plug is damaged, liquid has been spilled or objects have fallen into the device, the device has been exposed to rain or moisture, does not operate normally, or has been dropped.

Avertissement! Référez-vous au personnel de service qualifié pour tout entretien. L'entretien est exigé quand l'appareil a été endommagé de quelque manière que ce soit, par exemple lorsque le cordon d'alimentation ou la prise sont endommagés, que du liquide a été versé ou des objets sont tombés dans l'appareil, que l'appareil a été exposé à la pluie ou à l'humidité, ne fonctionne pas normalement ou est tombé.

Warnung! Das Gerät sollte nur von qualifizierten Fachkräften gewartet werden. Eine Wartung ist fällig, wenn das Gerät in irgendeiner Weise beschädigt wurde, wie bei beschädigtem Netzkabel oder Netzstecker, falls Flüssigkeiten oder Objekte in das Gerät gelangen, das Gerät Regen oder Feuchtigkeit ausgesetzt wurde, nicht ordnungsgemäß funktioniert oder fallen gelassen wurde.

¡Advertencia! Consulte al personal calificado por cuestiones de reparación. El servicio de reparación se requiere cuando el dispositivo ha recibido cualquier tipo de daño, por ejemplo cable o espigas dañadas, se ha derramado líquido o se han caído objetos dentro del dispositivo, el dispositivo ha sido expuesto a la lluvia o humedad, o no funciona de modo normal, o se ha caído.

Aviso! Remeta todos os serviços de manutenção para o pessoal de assistência qualificado. A prestação de serviços de manutenção é exigida quando o dispositivo foi danificado mediante qualquer forma, como um cabo de alimentação ou ficha que se encontra danificado/a, quando foi derramado líquido ou caíram objectos sobre o dispositivo, quando o dispositivo foi exposto à chuva ou à humidade, quando não funciona normalmente ou quando foi deixado cair.

Avviso! Fare riferimento al personale qualificato per tutti gli interventi di assistenza. L'assistenza è necessaria quando il dispositivo è stato danneggiato in qualche modo, ad esempio se il cavo di alimentazione o la spina sono danneggiati, è stato rovesciato del liquido è stato rovesciato o qualche oggetto è caduto nel dispositivo, il dispositivo è stato esposto a pioggia o umidità, non funziona correttamente o è caduto.



Warning! Do not defeat the safety purpose of the polarized or grounding-type plug. A polarized plug has two blades with one wider than the other. A grounding type plug has two blades and a third grounding prong. The wide blade or the third prong are provided for your safety. If the provided plug does not fit into your outlet, consult an electrician for replacement of the obsolete outlet.

Avertissement! La sécurité de la prise polarisée ou de la prise de type mise à la terre ne doit en aucun cas être empêchée de fonctionner. Une prise polarisée a deux broches, l'une étant plus large que l'autre. Une prise de type mise à la terre a deux broches et une troisième broche pour la mise à la terre. La broche large ou la troisième broche sont fournies pour votre sécurité. Si la prise fournie ne s'insère pas dans votre prise femelle, consultez un électricien pour le remplacement de la prise femelle obsolète.

Warnung! Der Sicherheitszweck des gepolten bzw. Schukosteckers ist zu berücksichtigen. Ein gepolter Stecker verfügt über zwei Pole, von denen einer breiter als der andere ist. Ein Schukostecker verfügt neben den zwei Polen noch über einen dritten Pol zur Erdung. Der breite Pol bzw. der Erdungspol dienen der Sicherheit. Wenn der zur Verfügung gestellte Stecker nicht in Ihren Anschluss passt, konsultieren Sie einen Elektriker, um den veralteten Anschluss zu ersetzen.

¡Advertencia! No eche por tierra la finalidad del tipo de enchufe polarizado con conexión a tierra. Un enchufe polarizado tiene dos espigas, una más ancha que la otra. Un enchufe con conexión a tierra tiene dos espigas iguales y una tercera espiga que sirve para la conexión a tierra. La espiga ancha, o la tercera espiga, sirven para su seguridad. Si el enchufe suministrado no encaja en el tomacorriente, consulte con un electricista para reemplazar el tomacorriente obsoleto.

Aviso! Não anule a finalidade da segurança da ficha polarizada ou do tipo ligação terra. Uma ficha polarizada tem duas lâminas sendo uma mais larga do que a outra. Uma ficha do tipo de ligação à terra tem duas lâminas e um terceiro terminal de ligação à terra. A lâmina larga ou o terceiro terminal são fornecidos para sua segurança. Se a ficha fornecida não couber na sua tomada, consulte um electricista para a substituição da tomada obsoleta.

Avviso! Non compromettere la sicurezza della spina polarizzata o con messa a terra. Una spina polarizzata ha due spinotti, di cui uno più largo. Una spina con messa a terra ha due spinotti e un terzo polo per la messa a terra. Lo spinotto largo o il terzo polo sono forniti per motivi di sicurezza. Se la spina fornita non si inserisce nella presa di corrente, contattare un elettricista per la sostituzione della presa obsoleta.



Warning! Since the Mains plug is used as the disconnection for the device, it must remain readily accessible and operable.

Avertissement! Puisque la prise principale est utilisée pour débrancher l'appareil, elle doit rester aisément accessible et fonctionnelle.

Warnung! Da der Netzstecker als Trennvorrichtung dient, muss er stets zugänglich und funktionsfähig sein.

¡Advertencia! Puesto que el enchufe de la red eléctrica se utiliza como dispositivo de desconexión, debe seguir siendo fácilmente accesible y operable.

Aviso! Dado que a ficha principal é utilizada como a desconexão para o dispositivo, esta deve manter-se prontamente acessível e funcional.

Avviso! Poiché il cavo di alimentazione viene usato come dispositivo di sconnessione, deve rimanere prontamente accessibile e operabile.



Warning! Protect the power cord from being walked on or pinched particularly at plugs, convenience receptacles, and the point where they exit from the device.

Avertissement! Protégez le cordon d'alimentation pour que l'on ne marche pas dessus ou qu'on le pince, en particulier au niveau des prises mâles, des réceptacles de convenance, et à l'endroit où il sort de l'appareil.

Warnung! Vermeiden Sie, dass auf das Netzkabel getreten oder das Kabel geknickt wird, insbesondere an den Steckern, den Steckdosen und am Kabelausgang am Gerät.

¡Advertencia! Proteja el cable de corriente para que no se le pise ni apriete, en especial cerca del enchufe, los receptáculos de conveniencia y el punto del que salen del equipo.

Aviso! Proteja o cabo de alimentação de ser pisado ou de ser comprimido particularmente nas fichas, em tomadas de parede de conveniência e no ponto de onde sai do dispositivo.

Avviso! Proteggere il cavo di alimentazione in modo che nessuno ci cammini sopra e che non venga schiacciato soprattutto in corrispondenza delle spine e del punto in cui esce dal dispositivo.



Warning! Disconnect the external AC power supply line cord(s) from the mains power before moving the unit.

Avertissement! Retirez le ou les cordons d'alimentation en CA de la source d'alimentation principale lorsque vous déplacez l'appareil.

Warnung! Trennen Sie die Wechselstrom-Versorgungskabel vom Netzstrom, bevor Sie das Gerät verschieben.

¡Advertencia! Cuando mueva la unidad desenchufe de la red eléctrica el/los cable(s) de la fuente de alimentación CA tipo brick.

Advertência! Remova os cabos CA de alimentação brick da rede elétrica ao mover a unidade.

Avvertenza! Scollegare il cavo dell'alimentatore quando si sposta l'unità.

3 Year Warranty and Liability Information

Limited Warranty on Hardware

AJA Video Systems, Inc. (AJA Video) warrants that the hardware product, not including storage modules or software components, will be free from defects in materials and workmanship for a period of three years from the date of purchase. AJA Video warrants that the storage modules provided as part of the hardware product will be free from defects in materials and workmanship for a period of one year from the date of purchase. AJA Video provides a separate software warranty as part of the license agreement applicable to software components.

If the Customer brings a valid claim under this limited warranty for a hardware product or storage module (hereafter, a "product") during the applicable warranty period, AJA Video will, at its sole option and as the Customer's sole remedy for breach of the above warranty, provide one of the following remedies:

- Repair or facilitate the repair the product within a reasonable period of time, free of charge for parts and labor.
- Replace the product with a direct replacement or with a product that performs substantially the same function as the original product.
- Issue a refund of the original purchase price less depreciation to be determined based on the age of the product at the time remedy is sought under this limited warranty.

To obtain service under this warranty, the Customer must notify AJA Video of the defect before expiration of the warranty period and make suitable arrangements for the performance of service by contacting AJA Video support through the channels set forth on the support contacts web page at <https://www.aja.com/support>.

Except as stated, the Customer shall bear all shipping, packing, insurance and other costs, excluding parts and labor, to effectuate repair. Customer shall pack and ship the defective product to a service center designated by AJA Video, with shipping charges prepaid. AJA Video shall pay to return the product to Customer, but only if to a location within the country in which the AJA Video service center is located. SOME JURISDICTIONS DO NOT ALLOW THE EXCLUSION OF IMPLIED WARRANTIES OR LIMITATIONS ON APPLICABLE STATUTORY RIGHTS OF A CONSUMER, SO SOME OR ALL OF THE TERMS OF THIS PARAGRAPH MAY NOT APPLY TO YOU.

Limitation of Liability

Under no circumstances shall AJA video BE LIABLE IN ANY WAY FOR ANY LOST, CORRUPTED OR DESTROYED DATA, FOOTAGE OR WORK, OR FOR ANY OTHER INDIRECT, SPECIAL, INCIDENTAL OR CONSEQUENTIAL DAMAGES OR LOST PROFITS, OR FOR ANY THIRD PARTY CLAIM, IN CONNECTION WITH THE PRODUCT, WHETHER RESULTING FROM DEFECTS IN THE PRODUCT, SOFTWARE OR HARDWARE FAILURE, OR ANY OTHER CAUSE WHATSOEVER, EVEN IF AJA VIDEO HAS BEEN ADVISED OF THE POSSIBILITY OF SUCH DAMAGES. AJA VIDEO'S LIABILITY IN CONNECTION WITH THE PRODUCT SHALL UNDER NO CIRCUMSTANCES EXCEED THE PURCHASE PRICE PAID FOR THE PRODUCT. The foregoing limitations apply even if any remedy set forth in this LIMITED WARRANTY fails of its essential purpose. SOME JURISDICTIONS DO NOT ALLOW THE LIMITATION OF LIABILITY FOR PERSONAL INJURY, OR OF INCIDENTAL OR CONSEQUENTIAL DAMAGES, SO SOME OR ALL OF THE TERMS OF THIS PARAGRAPH MAY NOT APPLY TO YOU.

Governing Law and Language; Your Rights

This limited warranty is the only warranty provided by AJA Video on the hardware product. It supersedes all prior or contemporaneous understandings regarding such subject matter. No amendment to or modification of this warranty will be binding unless in writing and signed by AJA Video. The laws of the State of California, USA will govern this warranty and any dispute arising from it. Any translation of this Agreement is intended for convenience and to meet local requirements and in the event of a dispute between the English and any non-English versions, the English version of this warranty will govern. This limited warranty gives you specific legal rights and you may have other rights that vary from jurisdiction to jurisdiction, some of which are noted above.

AJA Software License Agreement

AJA VIDEO SYSTEMS, INC.

THIS IS AN AGREEMENT BETWEEN YOU AND AJA VIDEO SYSTEMS, INC. ("AJA") THAT GOVERNS YOUR USE OF the software ACCOMPANYING THIS LICENSE (E.G., AS installed on the device with which this license is provided).

The "AJA Software" referenced in this Agreement includes all such software, whether made available to you on disk, in read only memory, on any other media or in any other form, and all updates, corrections, enhancements and new versions of such software made available by AJA, together with all related documentation. BY INSTALLING OR USING THE AJA SOFTWARE, YOU ARE AGREEING TO BE BOUND BY THE TERMS OF THIS AGREEMENT. IF YOU DO NOT AGREE TO THE TERMS OF THIS AGREEMENT, DO NOT INSTALL OR USE IT AND, IF APPLICABLE, RETURN THE AJA SOFTWARE TO THE PLACE WHERE YOU OBTAINED IT FOR A REFUND.

1. License Grant. AJA hereby grants you a nonexclusive, personal, non-sublicenseable and limited license to install and use AJA Software on a computer or AJA device. The foregoing license also includes the right to make copies of the AJA Software in machine-readable form for installation and backup purposes only, and provided that each copy you make must include all copyright or other proprietary notices contained on the original.

2. Limitations. You may not decompile, reverse engineer, disassemble, modify, or create derivative works of the AJA Software or any part thereof except to the extent (if any) authorized by applicable law notwithstanding the foregoing restriction. You may not rent, lease, lend, loan, distribute or act as a service bureau or "cloud service" provider with respect to use of the AJA Software or any functionality thereof. THE AJA SOFTWARE IS NOT INTENDED FOR USE IN THE OPERATION OF NUCLEAR FACILITIES, AIRCRAFT NAVIGATION OR COMMUNICATION SYSTEMS, AIR TRAFFIC CONTROL SYSTEMS, LIFE SUPPORT MACHINES OR OTHER EQUIPMENT IN WHICH THE FAILURE OF THE AJA SOFTWARE COULD LEAD TO DEATH, PERSONAL INJURY, OR SEVERE PHYSICAL OR ENVIRONMENTAL DAMAGE.

3. Reservation of Rights. The AJA Software is protected by law, including without limitation copyright law. The AJA Software is licensed, not sold, to you. AJA and its licensors reserve all rights not expressly granted to you by this Agreement. You own the media on which the AJA Software is recorded but AJA and/or AJA's licensor(s) retain ownership of the AJA Software itself. You may not use the AJA Software for any illegal purpose.

4. Transfer. You may make a one-time permanent transfer of all of your license rights to the AJA Software to another person or entity, provided that: (a) you transfer all of the AJA Software, including all its component parts, original media, printed materials and this Agreement; (b) you do not retain any copies of the AJA Software, including any copies stored on a computer or other device; and (c) you transfer the AJA Software subject to this Agreement, and the person or entity receiving the AJA Software accepts the terms and conditions of this Agreement.

5. NFR (Not for Resale) Copies and Add-On Features: Notwithstanding anything to the contrary in this Agreement, (a) AJA Software that is labeled "Not for Resale" or otherwise provided to you on a promotional or demonstration basis may be used only for your demonstration, testing and evaluation purposes and may not be resold or transferred; and (b) AJA may make available certain software components ("Add-On Features") under separate terms and conditions, in which case those separate terms and conditions apply and the Add-On Features are not considered AJA Software under this Agreement.

6. Termination. Your rights in the AJA Software are conditioned on complying with this Agreement, and those rights (together with this Agreement) will terminate automatically, without notice from AJA, if you fail to comply with any term(s) of this Agreement. Upon termination of this Agreement, you must cease all use of the AJA Software and destroy all copies, full or partial, of the AJA Software in your possession or control.

7. Limited Warranty on AJA Software. If you comply with all terms of this Agreement and use the AJA Software in accordance with its documentation, and you install any patches or other updates made available to the AJA Software by AJA, AJA warrants that the AJA Software will perform substantially in accordance with its documentation for a period of ninety (90) days from the date of your original retail purchase. Your exclusive remedy under this warranty will be, at AJA's option, a refund of the purchase

price of the product containing the AJA Software or an update to or replacement of the AJA Software (or applicable component of it). THIS LIMITED WARRANTY AND ANY IMPLIED WARRANTIES ON THE AJA SOFTWARE INCLUDING, BUT NOT LIMITED TO, ANY WARRANTIES OF MERCHANTABILITY, OF SATISFACTORY QUALITY, OR OF FITNESS FOR A PARTICULAR PURPOSE, ARE LIMITED IN DURATION TO NINETY (90) DAYS FROM THE DATE OF ORIGINAL RETAIL PURCHASE. SOME JURISDICTIONS DO NOT ALLOW LIMITATIONS ON HOW LONG A WARRANTY LASTS, SO THE ABOVE LIMITATION MAY NOT APPLY TO YOU. THIS LIMITED WARRANTY GIVES YOU SPECIFIC LEGAL RIGHTS, AND YOU MAY ALSO HAVE OTHER RIGHTS WHICH VARY BY JURISDICTION.

8. Disclaimer of Other Warranties on Aja Software. EXCEPT FOR THE LIMITED WARRANTY ON AJA SOFTWARE SET FORTH ABOVE, AJA AND AJA'S LICENSORS (COLLECTIVELY REFERRED TO AS "AJA" FOR THE PURPOSES OF SECTIONS 8 AND 9) HEREBY DISCLAIM ALL WARRANTIES AND CONDITIONS WITH RESPECT TO THE AJA SOFTWARE, WHETHER EXPRESS, IMPLIED OR STATUTORY, INCLUDING, BUT NOT LIMITED TO, THE IMPLIED WARRANTIES AND/OR CONDITIONS OF MERCHANTABILITY, OF SATISFACTORY QUALITY, OF FITNESS FOR A PARTICULAR PURPOSE, OF ACCURACY, AND OF QUIET ENJOYMENT. FURTHER, AJA DOES NOT MAKE ANY WARRANTY REGARDING NON-INFRINGEMENT OF THIRD PARTY RIGHTS. SUBJECT ONLY TO THE LIMITED WARRANTY SET FORTH IN SECTION 7, YOU EXPRESSLY ACKNOWLEDGE AND AGREE THAT USE OF THE AJA SOFTWARE IS AT YOUR SOLE RISK. AJA DOES NOT WARRANT AGAINST INTERFERENCE WITH YOUR ENJOYMENT OF THE AJA SOFTWARE, THAT THE AJA SOFTWARE WILL MEET YOUR REQUIREMENTS, THAT THE OPERATION OF THE AJA SOFTWARE WILL BE UNINTERRUPTED OR ERROR-FREE, OR THAT DEFECTS IN THE AJA SOFTWARE WILL BE CORRECTED. NO ORAL OR WRITTEN INFORMATION OR ADVICE GIVEN BY AJA OR AN AJA AUTHORIZED REPRESENTATIVE WILL CREATE A WARRANTY. SOME JURISDICTIONS DO NOT ALLOW THE EXCLUSION OF IMPLIED WARRANTIES OR LIMITATIONS ON APPLICABLE STATUTORY RIGHTS OF A CONSUMER, SO SOME OR ALL OF THE TERMS OF THIS PARAGRAPH MAY NOT APPLY TO YOU.

9. Limitation of Liability. TO THE EXTENT NOT PROHIBITED BY LAW, IN NO EVENT WILL AJA BE LIABLE FOR PERSONAL INJURY, OR ANY INCIDENTAL, SPECIAL, INDIRECT OR CONSEQUENTIAL DAMAGES OR LOST PROFITS WHATSOEVER, INCLUDING, WITHOUT LIMITATION, DAMAGES FOR LOSS OF DATA, BUSINESS INTERRUPTION OR ANY OTHER COMMERCIAL DAMAGES OR LOSSES, ARISING OUT OF OR RELATED TO YOUR USE OR INABILITY TO USE THE AJA SOFTWARE, HOWEVER CAUSED, REGARDLESS OF THE THEORY OF LIABILITY (E.G., WHETHER UNDER CONTRACT, TORT OR OTHERWISE) AND EVEN IF AJA HAS BEEN ADVISED OF THE POSSIBILITY OF SUCH DAMAGES. In no event will AJA's total liability to you for all damages (INCLUDING WITHOUT LIMITATION BREACH OF WARRANTY) exceed the amount of fifty dollars (\$50.00). The foregoing limitations will apply even if the any remedy set forth in this agreement fails of its essential purpose. SOME JURISDICTIONS DO NOT ALLOW THE LIMITATION OF LIABILITY FOR PERSONAL INJURY, OR OF INCIDENTAL OR CONSEQUENTIAL DAMAGES, SO SOME OR ALL OF THE TERMS OF THIS PARAGRAPH MAY NOT APPLY TO YOU.

10. Export Law Assurances. You may not use or otherwise export or reexport the AJA Software except as authorized by United States law and the laws of the jurisdiction in which the AJA Software was obtained. In particular, but without limitation, the AJA Software may not be exported or re-exported (a) into (or to a national or resident of) any U.S. embargoed countries, or (b) to anyone on the U.S. Treasury Department's list of Specially Designated Nationals or the U.S. Department of Commerce Denied Persons List or Entity List or any similar legal designation. By using the AJA Software, you represent and warrant that you are not located in, under control of, or a national or resident of any such country or on any such list.

11. Government End Users. The AJA Software including its documentation is a "Commercial Item", as that term is defined at 48 C.F.R. § 2.101, consisting of "Commercial Computer Software" and "Commercial Computer Software Documentation", as such terms are used in 48 C.F.R. § 12.212 or 48 C.F.R. § 227.7202 (or their successors), as applicable. Consistent with these provisions, the AJA Software is licensed to U.S. Government end users (a) only as a Commercial Item and (b) with only those rights as are granted to all other end users pursuant to this Agreement. Unpublished-rights reserved under the copyright laws of the United States.

12. Controlling Law and Severability. This Agreement will be governed by and construed in accordance with the laws of the State of California, as applied to agreements entered into and to be performed entirely within California between California residents. This Agreement will not be governed by the United Nations

Convention on Contracts for the International Sale of Goods, the application of which is expressly excluded. If for any reason a court of competent jurisdiction finds any provision, or portion thereof, to be unenforceable, the remainder of this Agreement will continue in full force and effect.

13. Complete Agreement; Governing Language. This Agreement constitutes the entire agreement between the parties with respect to the use of the AJA Software licensed hereunder and supersedes all prior or contemporaneous understandings regarding such subject matter. No amendment to or modification of this Agreement will be binding unless in writing and signed by AJA. Any translation of this Agreement is intended for convenience and to meet local requirements and in the event of a dispute between the English and any non-English versions, the English version of this Agreement will govern.

Index

Symbols

- 2SI Alignment 25
- 3rd-Party Plugins 8
- 3 Year Warranty and Liability Information 68

A

- AJA Control Panel 8
- AJA Control Room 8
- AJA Device Drivers 8
- AJA Software License Agreement 69
- AJA Software & Utilities 7
- AJA Support 2
- AJA System Test 10
- Application
 - Controlling KONA 22
- ATX Power 14
- Audio Input 27
- Audio Mixer Capture Monitor Tab 33
- Audio Mixer Playback Monitor Tab 34, 35
- Audio Mixer Screen 32
- Audio Pane 45
- Audio Setup Screen 31

B

- Block Diagram Area 18
- BMP Format 17

C

- Cable Connections 14
- Capture Formats 17
- Capture Mode 18
- CH1 Video SDP 45
- Ch Map 27
- Colorimetry 29
- Color Space 28, 30
- Controlling Application 22
- Control Network Statistics 57
- Control Panel 8, 17
 - Block Diagram Area 18
 - Framebuffer 20
 - Input/Output Icon 19
 - UI Colors 19
 - User Interface 18
- Control Room 8
- Control Screen
 - Standard Mode 24
- Custom LUT Controls 37

D

- Damage in Shipping 13
- Default Output 24
- Default Preferences 20
- Default State 24
- Delete Preset 40
- Device Drivers 8

- Device Format 20
- Digital Primaries 30
- Disk Storage Methods 9
- Downloading and Installing Updated Firmware 56
- DPX Format 17

E

- Ember+ Configuration 54
- Erase all Prefs 41
- Export 38

F

- Firmware
 - Downloading 56
 - Updating from Web UI 56
- Firmware Tab 56
- Follow Input 26
- Format 25
- Format Screen
 - Standard Mode 25
- Framebuffer
 - Control Panel UI 20

G

- Gamma 31
- Global Preference 21
- Global Preference File Location 21

H

- HDMI Screen
 - Standard Mode 29
- HDR Capture 29
- HDR Mode 30
- HDR Screen 29
- Hold Last App 24

I

- Information Screen
 - Standard Mode 41, 42
- Input/Output Icon 19
- Input/Output Icons 19
- Input Select Screen
 - Standard Mode 26
- Inserting KONA Card 15
- Installing Software 16

K

- KONA 5 ATX Power 14
- KONA Card
 - Inserting 15
 - Removing 15

L

- Load Preset 40
- Local Preference 21

- Luminance 29, 30
- LUT File 39
- LUT File Format Specification 39
- LUT Gain and Offset Controls 38
- LUT Screen 37
- LUT Type 38

M

- macOS Installations 16
- Media 1 and Media 2 Network Statistics 57
- Media 1, Media 2 Panes 52
- Modes of Operation 17
- MOV Format 17
- Multicast 6
- Multiple AJA Devices 22
- MXF Format 17

N

- Network Requirements 8
- Network Statistics Control Pane 57
- Network Statistics Media 1 and Media 2 Panes 57
- Network Tab Controls 51
- NMOS 7
- NMOS Configuration 53
- Notes on Using Multiple AJA Products 23

O

- Operating Modes 17
- Output Select Screen 28
- Overview 5

P

- Pass Through (Cap) 24
- Pixel Format 26
- Playback Mode 18
- Playback Source Selection 34
- Preference 20
- Preference File Location
 - Default Global 21
- Preset
 - Delete 40
 - Load 40
 - Save 40
- Preset Files Storage Location 20, 40
- Presets 20
- Presets Screen 40
- Primary Format 25
- Primary & Secondary Rx 46
- Progressive Pref 30

Q

- QuickTime Format 17

R

- Reference Clock 9
- Removing KONA Card 15
- Reset to Default 41
- RGB Range 26, 28

S

- Save Preset 40
- SDI RGB Rng 27
- SFP Cage 9
- SFP Module 9, 15
- Shared Preference
 - File Location 21
- Shipping Box Contents 13
- Snapshot 40
- Software 7
- Software Download 16
- Software Installation 16
- Software Package Installation and Re-installation 16
- Source
 - Video Input 27
- ST2110-20 Video Configuration 46
- Supported SFP Models 5
- System Requirements 9
- System Tab Controls 55

T

- Test Pattern 24, 25
- TGA Format 17
- Third-Party Application 16
- Transferring Saved Presets 40

U

- Unicast 6
- Update
 - Firmware Screen 56
- Uploading Custom User LUT file 39
- Utilities 7

V

- Video Input 27
- Video Setup 30
- Video Setup Screen 30